

2024 FHEA FALL EXPO



Exploring Campus wide UPS deployment and
how it effects Total Cost of Ownership

2024 FHEA FALL EXPO TALK



TRAINING

Presenter : Michael Sheppard
Regional Sales Manager

E-Mail:

michael.sheppard@piller.com

Phone:

312-802-1187

Campus wide UPS deployment

Cost of Ownership

- ❑ UPS Definition of Terms
- ❑ UPS Technology
- ❑ UPS Topology
- ❑ UPS Cost of Ownership
 - ❑ UPS footprint
 - ❑ UPS Efficiency
 - ❑ UPS Maintenance and Downtime
 - ❑ UPS Reliability and Availability
- ❑ Summary
- ❑ Q&A



2024 FHEA FALL EXPO TALK



TRAINING

UPS Terms

- **Static UPS** - A static inverter feeding the load
- **Battery** – energy storage
- **Flywheels** – energy storage
- **Super CAPS** – energy storage
- **Induction Coupling** – energy storage
- **Standby Generator** - Any UPS can be used in conjunction with or without Diesel
- **Rotary UPS** - During all modes of operation for a Rotary UPS, the load is fed directly from a synchronous generator or motor generator. Hence, the distinction between a Static and a Rotary does not lie in the use of batteries or flywheels as a short-term emergency power source; rather it is based on the method through which the output power is derived” - **2008 Frost and Sullivan**

2024 FHEA FALL EXPO TALK



TRAINING

UPS Technology

Static UPS

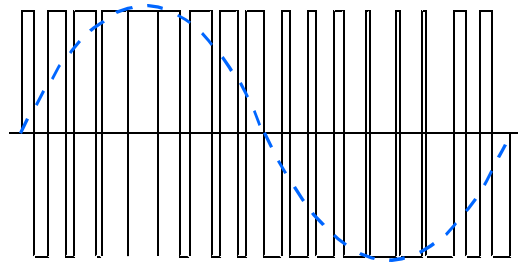
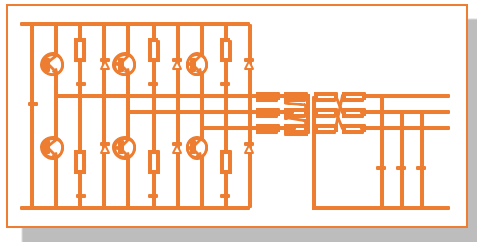

- Artificial sine-wave generated by power electronics; thyristors, rectifiers or IGBT's (Isolated Gate Bipolar Transistors). These IGBTs are used to achieve high power output....side effect is increased switching and conduction losses
- Uses DSP as control device to sample waveform and PWM to create an average of pulses that when passed through a filter recreates the artificial sinewave on output
- Large number of smoothing Power Capacitors associated (5-8 year replacement typical)
- Redundant electric fans are required for cooling (8-10 replacement typical)

Rotary UPS

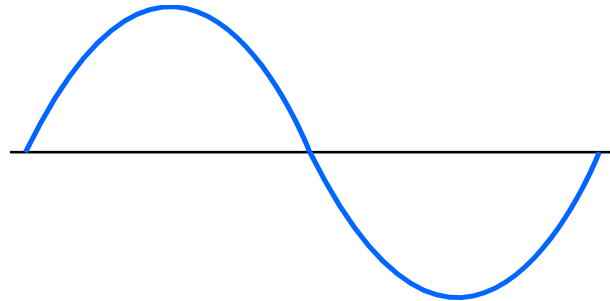
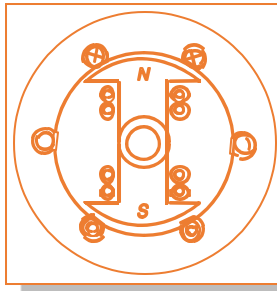

Natural sine-wave generated by modern, robust electrical machines in combination with reliable redundant power-electronics.

- No requirement for paralleled power electronics
- No smoothing power capacitors are required - anywhere
- No power filters required
- System is naturally cooled by integral fan on M/G set

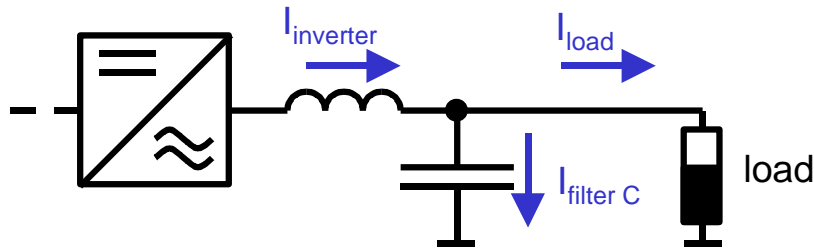

Static UPS

- IGBT inverter output filter is required to change the PWM to a sinusoidal waveform.
- Capacitor supplies reactive power to a load with a lagging power factor.
- Loads with leading Pf put a higher load on the inverter than rated.

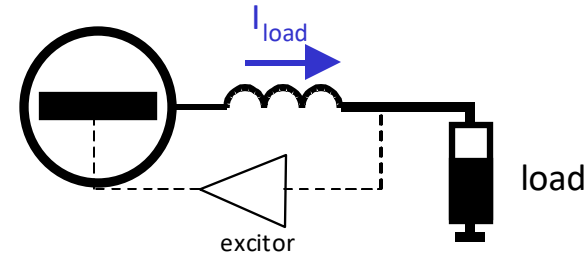

Rotary UPS

- The generator needs no waveform filtering.
- The generator reactive current is variable through regulation of the field current (by increasing or decreasing excitation) **This regulates the voltage seen by the load.**
- This means the generator can **supply or absorb** reactive power to/from the load without exceeding rated capacity ...load Pf has no effect on input

Static UPS

Artificial sine-wave generated by power electronics, Using IGBT's (Isolated Gate Bipolar Transistors)

Typically 750KVA/KW-1200KVA/KW Module Size
(Made up of paralleled 200-300KVA/KW inverter stages)

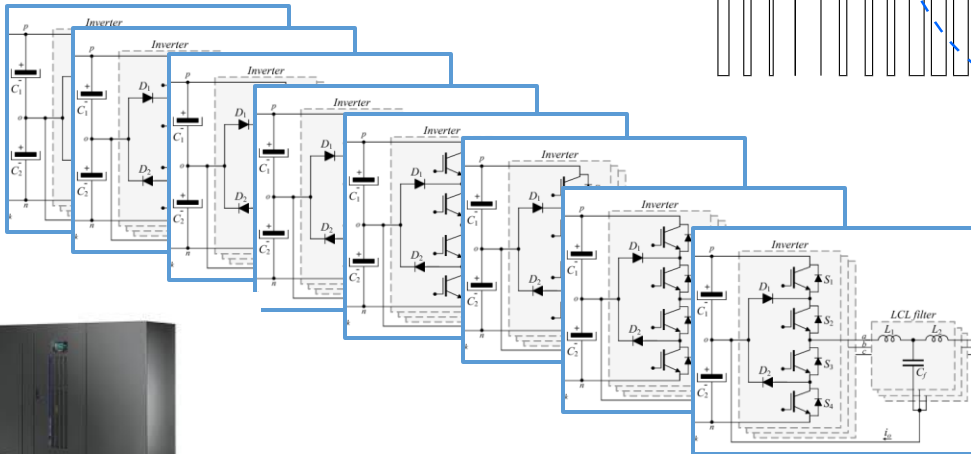
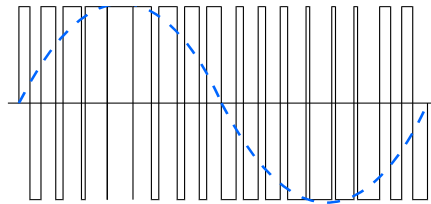

Example: A 2MW (2x1000KW) Static UPS will consist of at a minimum 8 x 250KW inverter stages, 192 IGBT Devices, 8 DC Capacitor Banks and 8 Filter circuits

Multiple Cooling fans are required to extract switching losses and heat

Rotary UPS

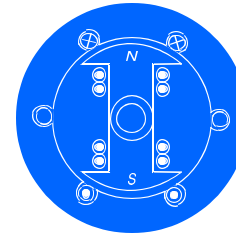

$$z = x + iy = r(\cos \varphi + i \sin \varphi)$$

$$x = r \cos \varphi$$

$$y = r \sin \varphi$$

$$\varphi = \omega t$$

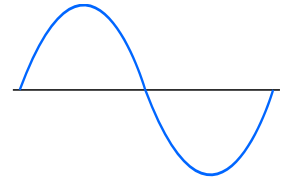
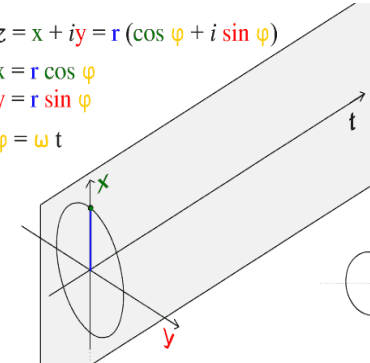

Natural sine-wave generated by modern, robust electrical machine in combination with reliable power-electronics

Single Entity Unit size up to 3600/3240 kVA/KW

Natural cooling eliminates the need for fans

Natural Sine Wave generation eliminates the need for capacitors and filter circuits

Example: A 2000KW Rotary UPS is a single entity machine using no capacitors or filter circuits

2024 FHEA FALL EXPO TALK

TRAINING

UPS Topology



UPS Topology

Configuration



What UPS topology is available in the market today?

There are the **TWO** fundamental UPS topologies available.

The UPS topology is best differentiated by the way in which the energy transfers between storage and UPS

A UPS topology is not defined by the type of energy storage (battery, flywheel, capacitor,...)



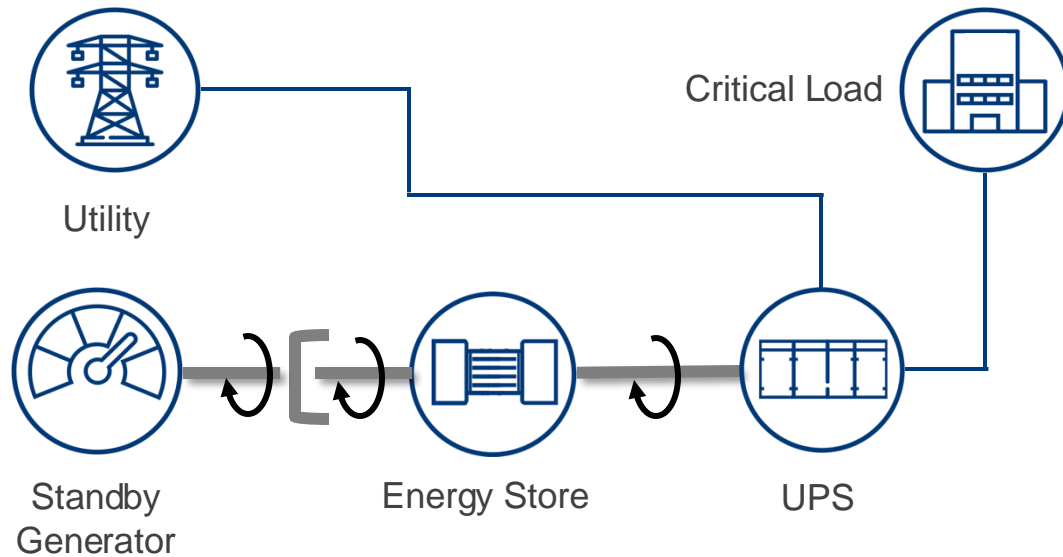

Mechanically Coupled (MC)

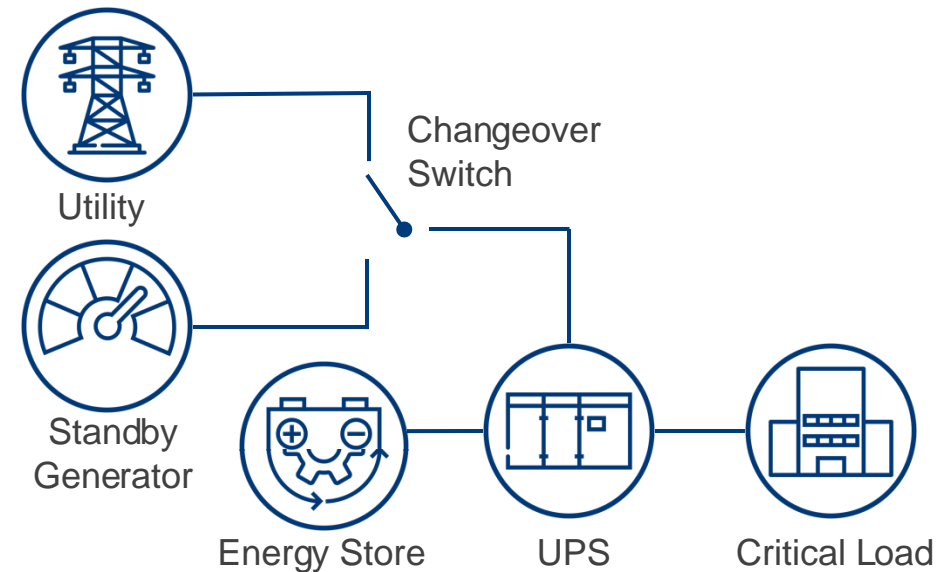

Electrically Coupled (EC)



The power required by UPS systems for bridging mains failures can be provided in different ways:

-  Battery
-  Flywheel
-  Capacitor
-  Compressed air
-  Superconducting coil (SMES)

UPS Topology

Energy Storage

Lead Acid Battery	Li-Ion Battery	Flywheel
Material = plastic, acid, lead recyclable	Material must be recycled - unclear	Material=copper, steel 100% recyclable
Toxic components	Highly toxic components	Non toxic components
Limited transport – battery-dependent	Transport of dangerous goods	Standard transport without any restrictions
Air conditioning coolants	Thermo-management	No requirements
Flammable	Flammable	Not flammable
5-8 years life time	Up to 15 years is estimated life time	over 15 years life time

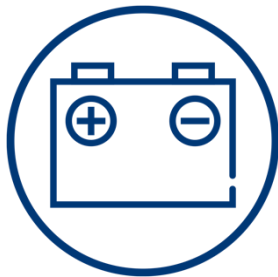

PLASTIC / LEAD / ACID



PLASTIC / ALUMINIUM /
COBALT + MANGAN / LITHIUM



STEEL / COPPER

UPS Topology

Mechanically Coupled (MC) UPS

System configuration:

- ❑ All MC UPS manufacturers are using a similar system configuration
- ❑ Generator, energy storage device, Diesel engine and several other components are installed on the same shaft
- ❑ Several bearings

Induction coupling:

- ❑ 2 rotating parts running with different speed in the same housing
- ❑ Low energy storage capacity (~ 6MJ)
- ❑ Short bridging time results in high wear and tear of all the components

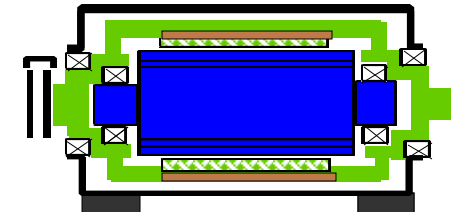
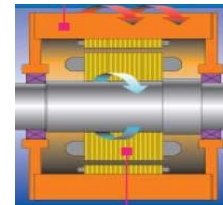
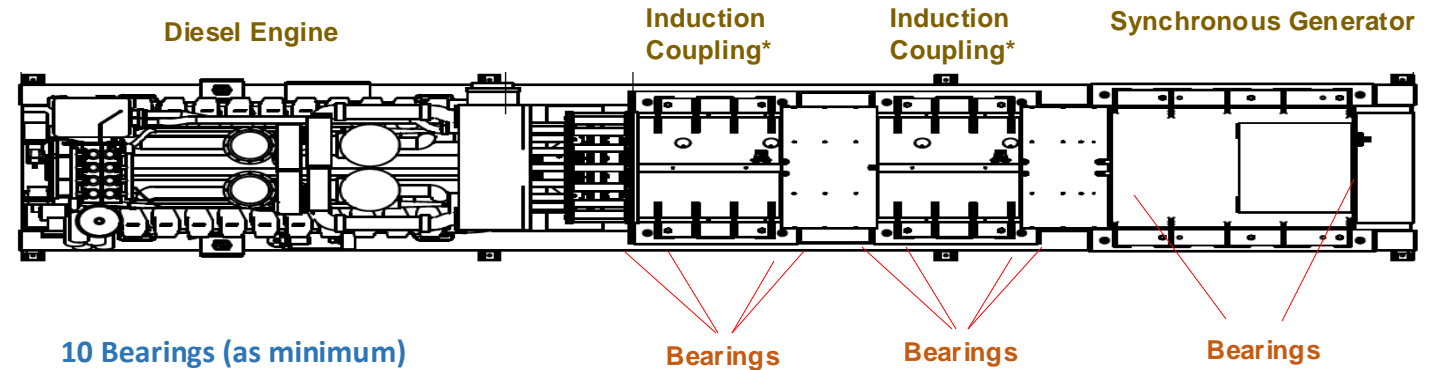

UPS Topology

Electrically Coupled Rotary (EC) UPS

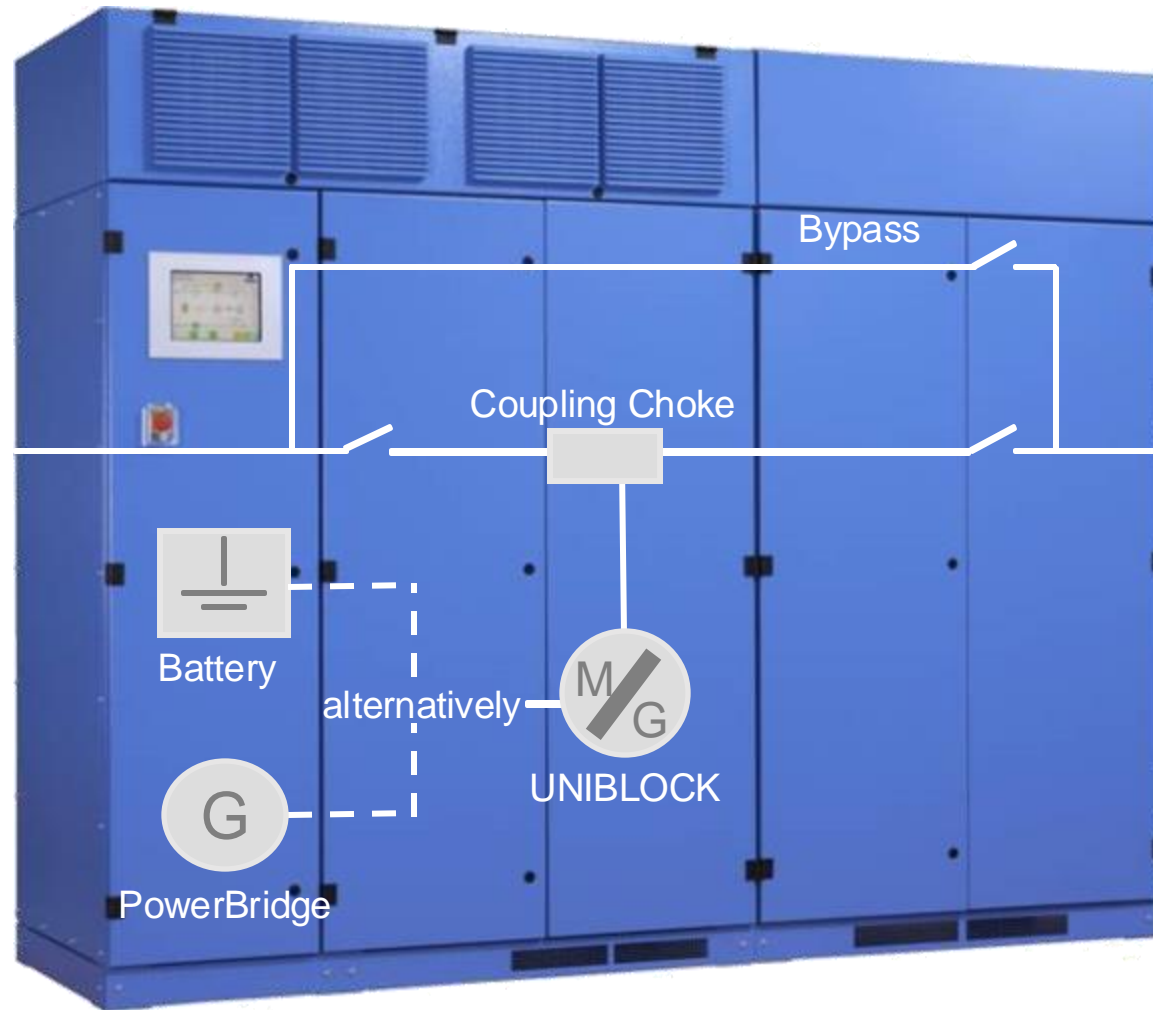

Rotary UPS (typical) range:

Frequency: 50, 60Hz

Voltage: LV, MV Application

Ratings:

- Up to 3.6MVA for a Single Module
- Parallel Application

System Configurations: Various

UPS Topology

Electrically Coupled Static (EC) UPS



PILLER
Power Systems

Typical range:

Frequency: 50, 60Hz

Voltage: Low Voltage

Energy Storage: Battery (Typically)

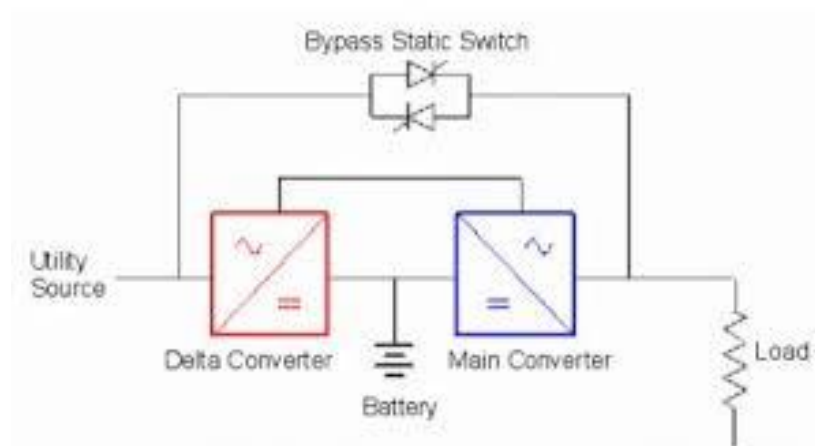

Ratings: up to 2MW in a single enclosure

System Configurations: Various

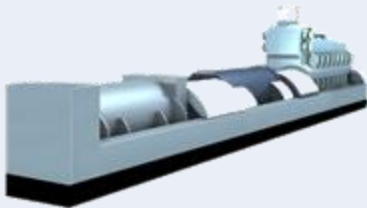

UPS Topology

Topology configuration and Energy Storage review

UPS Type	Mechanically Coupled (MC UPS)	Electrically Coupled UPS (EC UPS)	
Nomenclature	<i>DRUPS</i>	<i>Rotary UPS (RUPS)</i>	<i>Static UPS</i>
Output waveform production	Natural generation	Natural generation	Synthesized generation
Stored energy transfer	Mechanical via driveshaft	Power electronics	
Energy Storage option	Kinetic Energy	Battery or Kinetic Energy	
Backup Generation	Direct at UPS	Downstream, or Upstream of UPS	Upstream of UPS
Design Criteria	20 Years	25+ Years	10-12 Years
			
	Not seen in large Data Center Application	Highest Flexibility Various UPS and Generator System Configurations	

UPS Topology

Medium Voltage Consideration

There is a limit
beyond which
low voltage
cannot
practically be
used

More systems
means more
infrastructure,
more failures,
more cost

This limitation
does not apply
at medium
voltage

UPS Topology

Typical deployment for Medium Voltage Application

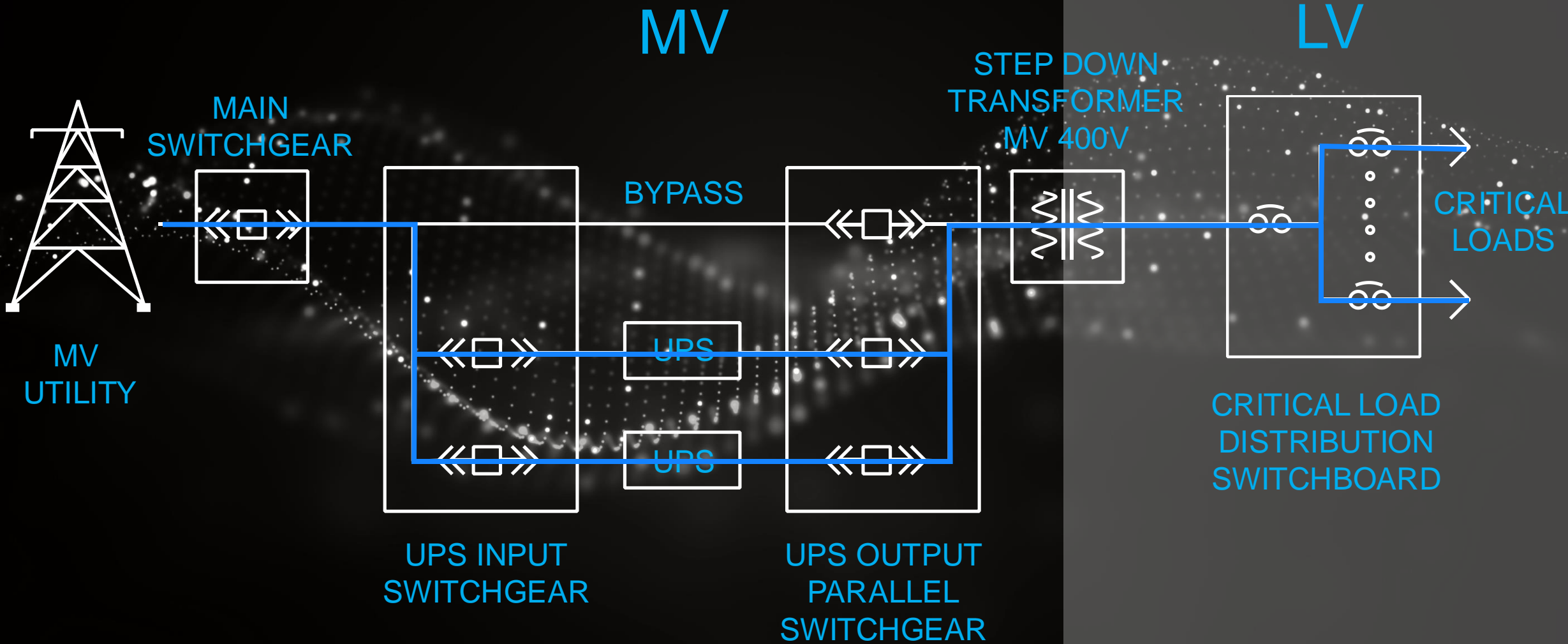

UPS Topology

Losses - LV solution vs HV solution

The schemes are showing the typical losses of 3 different configurations for a 10 MVA distribution.

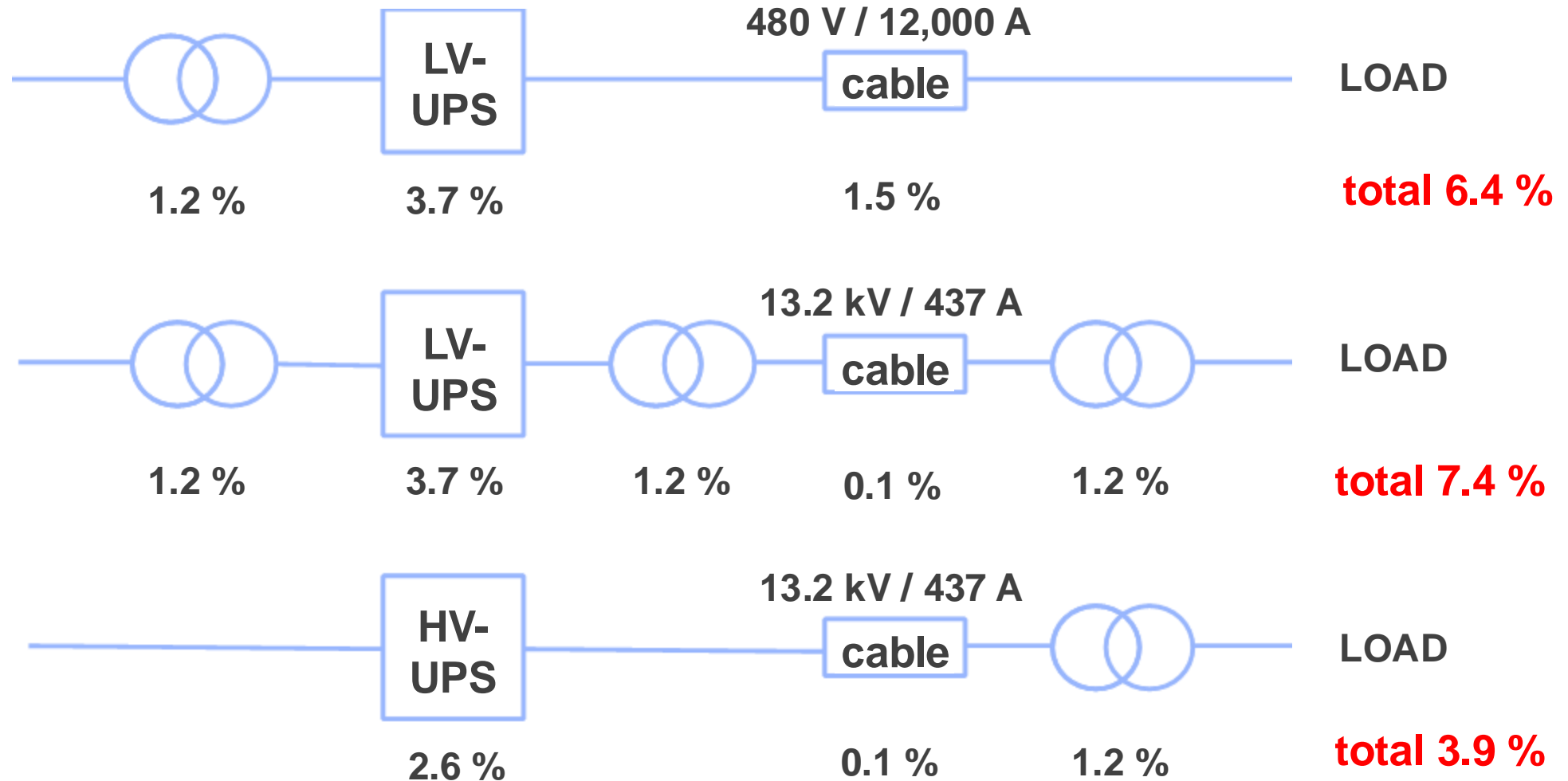

UPS Topology

Material Consideration

Feeder rationalisation



Large systems allow transformer consolidation

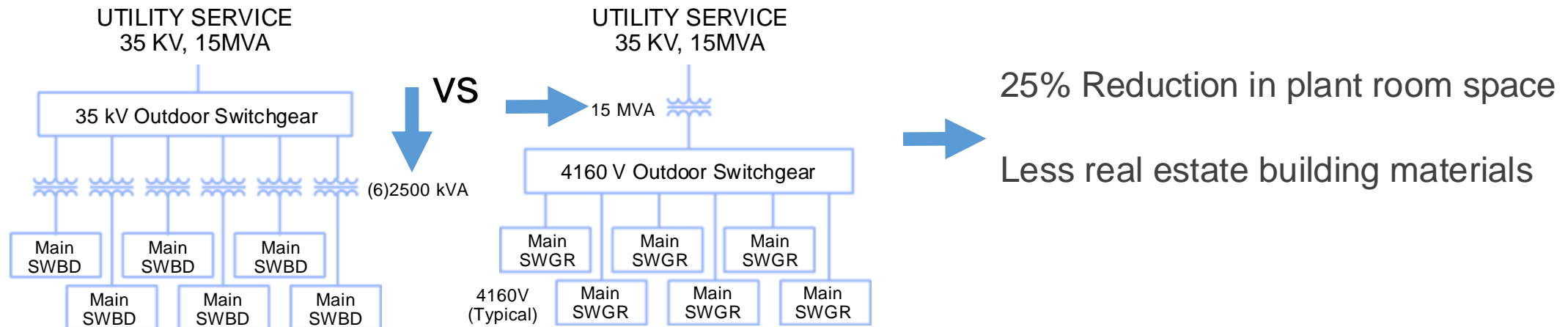

UPS Topology

Energy



Mutual Heating



No Mutual Heating

Cable grouping and mutual heating lead to higher losses

Transformer losses cut by 60%

Feeder losses reduced by a factor of 50

'Grid to rack' losses reduced significantly

UPS Topology

Consideration of HV deployment – other benefits

Breaker Reliability



600 Volt Insulated Case Breaker
Squared D Masterpact NW

MV Mag-Actuated Vacuum
Breaker ABB VM-1

Reliability Increases with HV Breakers

Can have lower arc flash than equivalent LV system

Maintenance is less

Heat-related Switchboard issues are less

Terminations are fewer

Costs can be less

Renewables – On HV network

Endurance Test Results:

- ❑ The best 480 V breaker performed nearly 25,000 operations before failure
- ❑ The best 4160 V breaker went over 70,000 operations before testing was stopped

2024 FHEA FALL EXPO TALK



TRAINING

UPS
Total Cost of Ownership
(TOC)

Direct Comparison between Key Technology Factors for TOC



PILLER
Power Systems

Footprint

**Reliability
and
Availability**

Efficiency

**Maintenance
and
Downtime**

**=
Total Cost
of
Ownership**

2024 FHEA FALL EXPO TALK



TRAINING

TOC
- Footprint

UPS Cost of Ownership Footprint

- Single entity Rotary UPS eliminates the need for multiple parallel power stages necessary in Static UPS
- Power per square metre up to 20% better
- Embodied carbon used in construction industry materials accounts for 11% of the world's green house gas emissions
- If a 20% reduction could be achieved throughout construction, then carbon dioxide emissions could be reduced by 750 Million Metric tons pa.

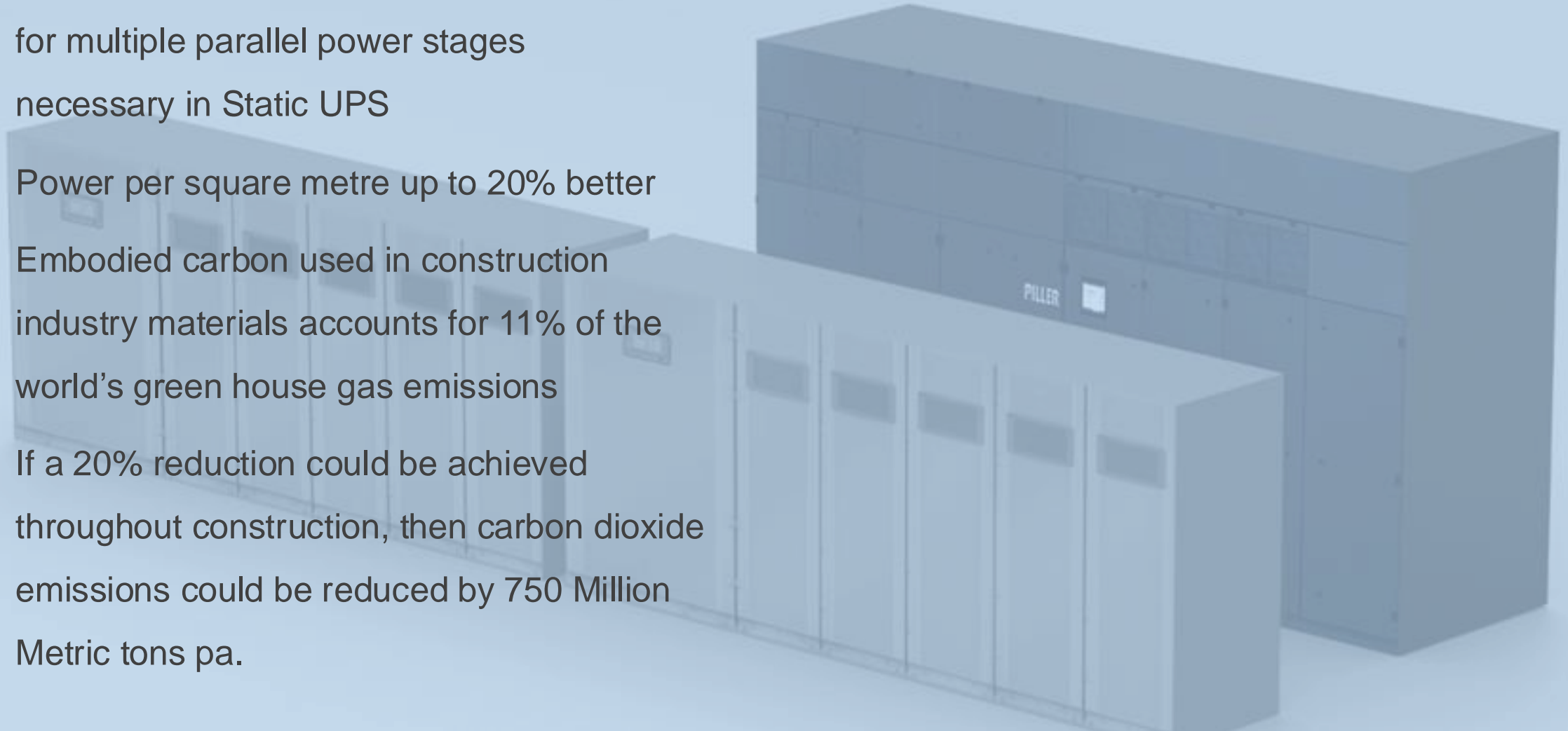

2024 FHEA FALL EXPO TALK

TRAINING

TOC
- Efficiency



Efficiency

Modern Static UPS have good online efficiencies

- High performance rotary UPS efficiency is better across the majority of loadings
- High performance rotary UPS has no internal paralleling
- Higher Static UPS efficiency is possible;
 - by switching between alternate modes (e.g. ECO), but this introduces risk and is not normally adopted, or
 - By ramping down converter stages to maintain a high percentage of load but this reduces short circuit capability, that could affect sub-circuit discrimination

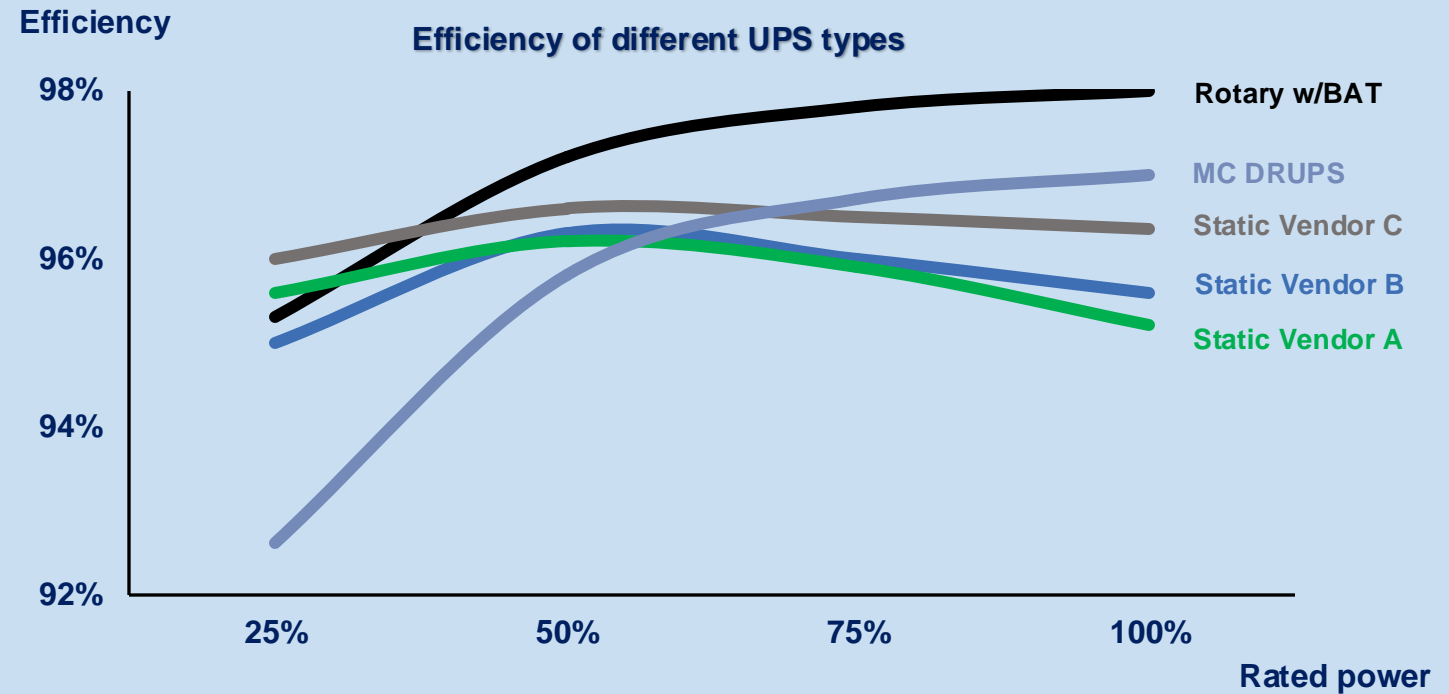

Efficiency

Electrical savings for 48MW IT Load:

- ❑ Modern Static UPS provide good efficiency with alternative modes, but this introduces risk and is not normally adopted

- ❑ High performance rotary UPS has higher efficiency across the common load factors

IT load kW 48,000		
Energy cost per kWh = \$0.10		
Efficiency	50% load	100% load
Rotary UPS	97.0%	98.0%
Static UPS	96.3%	96.3%
<i>10 Year savings with Rotary UPS</i>	\$1,575,500	\$7,574,300

Electrical savings for 48MW IT Load, based upon \$0.10 kWh energy cost

2024 FHEA FALL EXPO TALK

TRAINING

TOC

- Maintenance
- Downtime

Mechanically coupled(MC) UPS: DRUPS

- ❑ Extensive maintenance and overhauls with high intervention and downtime
- ❑ Annual offline maintenance / Major events
- ❑ High Stress / Complex Drive train Dynamics
- ❑ 20 Year Design Life

Monitoring/Reporting:

- ❑ Reactive Alarm Monitoring and log/reporting
- ❑ No virtual predictive maintenance

<i>Downtime (days) Over 10 years 2MW system</i>	Topology		
	MC DRUPS	EC Static UPS with Lion	EC UB-V* with Lion
Maintenance	15		
Fans/Capacitors	0		
Bearings	Incl in ES		
ES overhaul	2 x 5		
Clutch	2		
Battery replacements	0		
Total (days)	27		

EC UPS: Static UPS (typically paralleled inverter stages to increase capacity)

- ❑ High maintenance and downtime with increased capacity
- ❑ Annual Offline Maintenance / Major events
- ❑ Decreased reliability with increased capacity
- ❑ 10-12 Year Design Life

Monitoring/Reporting:

- ❑ Reactive Alarm Monitoring and log event/reporting
- ❑ Most Statics do not have predictive maintenance

<i>Downtime (days) Over 10 years 2MW system</i>	Topology		
	MC DRUPS	EC Static UPS with Lion*	EC UB-V** with Lion*
Maintenance	15	10	
Fans/Capacitors	0	3	
Bearings	Incl in ES	0	
ES overhaul	2 x 5	0	
Clutch	2	0	
Battery replacements	0	0	
Total (days)	27	13	

* Battery maintenance not required.

UPS Cost of Ownership

Maintenance and Downtime

EC UPS: UB-V single entity UPS (unlike Static UPS)

- ❑ Annual Online maintenance
- ❑ Offline maintenance interval every five years*
- ❑ No Capacitor or Fan Replacement
- ❑ Minimum service intervention
- ❑ Significantly higher Reliability and Availability
- ❑ 25 Year Design Life

*Based on clean climate-controlled data center or UPS room environment and part of Unity Service Pack Offering

<i>Downtime (days) Over 10 years 2MW system</i>	Topology		
	MC DRUPS	EC Static UPS with Lion*	EC UB-V** with Lion*
Maintenance	15	10	2
Fans/Capacitors	0	3	0
Bearings	Incl in ES	0	0
ES overhaul	2 x 5	0	0
Clutch	2	0	0
Battery replacements	0	0	0
Total (days)	27	13	2

** Based on climate-controlled Data Center or UPS Room environment / USP
* Battery maintenance not required.

UPS Cost of Ownership

Maintenance and Downtime



Downtime (days) Over 10 years 2MW system	Topology		
	MC DRUPS	EC Static UPS with Lion	EC UB-V* with Lion
Maintenance	15	10	2
Fans/Capacitors	0	3	0
Bearings	Incl in ES	0	0
ES overhaul	2 x 5	0	0
Clutch	2	0	0
Battery replacements	0	0	0
Total (days)	27	13	2

* Based on climate controlled Data Center or UPS Room environment / USP

** Battery maintenance not required.

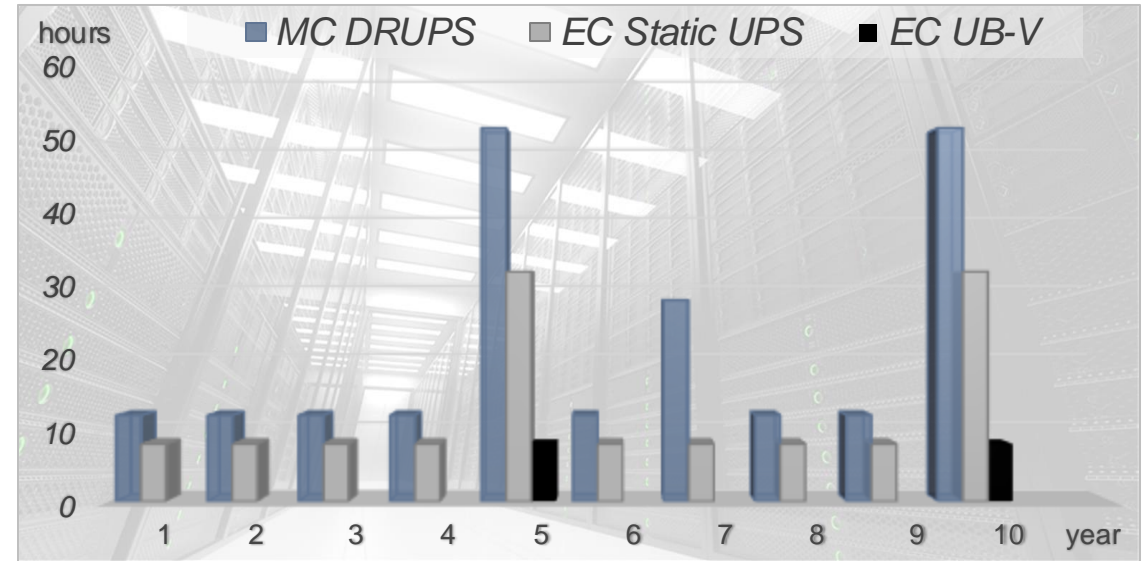

- ❑ The UB-V remains in operation and significantly reduces the costs, off-line periods and risks of maintenance.
- ❑ For Data Center clients – no need to inform customer base for UPS intervention
- ❑ The downtime of the UB-V Rotary is up to **13.5 times lower than** other UPS technologies

2024 FHEA FALL EXPO TALK





TRAINING

- TOC
- Reliability
 - Availability

UPS Cost of Ownership

UPS Reliability and Availability

UPS Type	Mechanically Coupled (MC UPS)	Electrically Coupled UPS (EC UPS)	
Nomenclature	<i>DRUPS</i>	<i>Rotary UPS (RUPS)</i>	<i>Static UPS</i>
Output waveform production	Natural generation	Natural generation	Synthesized generation
Stored energy transfer	Mechanical via driveshaft	Power electronics	
Energy Storage option	Kinetic Energy	Battery or Kinetic Energy	
Backup Generation	Direct at UPS	Downstream, or Upstream of UPS	Upstream of UPS
Design Criteria	20 Years	25+ Years	10-12 Years
			
	Not seen in large Data Center Application	Highest Flexibility Various UPS and Generator System Configurations	

Modular Static UPS



- ❑ Extensive internal paralleling to achieve high capacities
- ❑ High component count including Capacitors and Fans
 - ❑ Complex control and internal switching
- ❑ Higher intervention – fast hot swappable not realistic at 200kW (or higher) → higher MTTR than 50kW.

Typical Rotary UPS



- ❑ No internal paralleling of power electronics
 - ❑ No capacitors or fans
 - ❑ Resilient design
 - ❑ Minimum intervention
- ❑ Rotary UPS MTBF > 3,000,000 h

Monolithic Static UPS: 2,600,000 MTBF hours with bypass and 100,000 MTBF hours without bypass



Modular Static UPS 236,000 – 587,000 MTBF hours with bypass and as low as 41,500 hours without bypass!

18 Fans per 300kW Multi-module = 4X – for 72 fans for 1200kW UPS



UPS Cost of Ownership

UPS Reliability and Availability

Static UPS (EC) Rating – 1MW



PILLER
Power Systems

- Hundreds of Capacitors - 4X 300kW Multi-Module UPSs

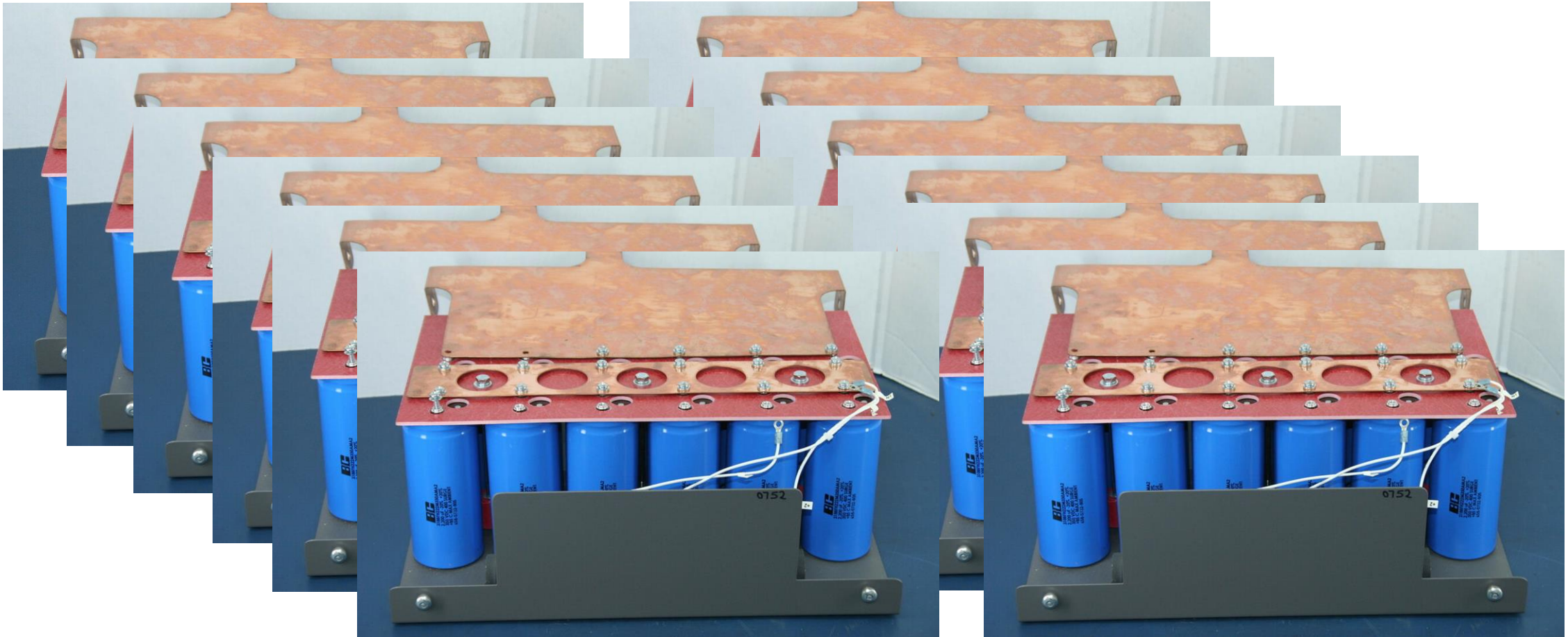

UPS Cost of Ownership

UPS Reliability and Availability

Static UPS (EC) Rating – 1MW



PILLER
Power Systems

Per Multi-Module – 3 Phase System

- 1 IGBT per phase (3) Input
- 1 IGBT per phase (3) Output
- For 1200kW Multi-Module UPS
- **24 Discreet components**



6 Inverters/Converters sections per 300kW Multi-Module – X4 – for 1200kW

UPS Reliability and Availability

Static UPS (EC) Rating – 2MW



PILLER
Power Systems

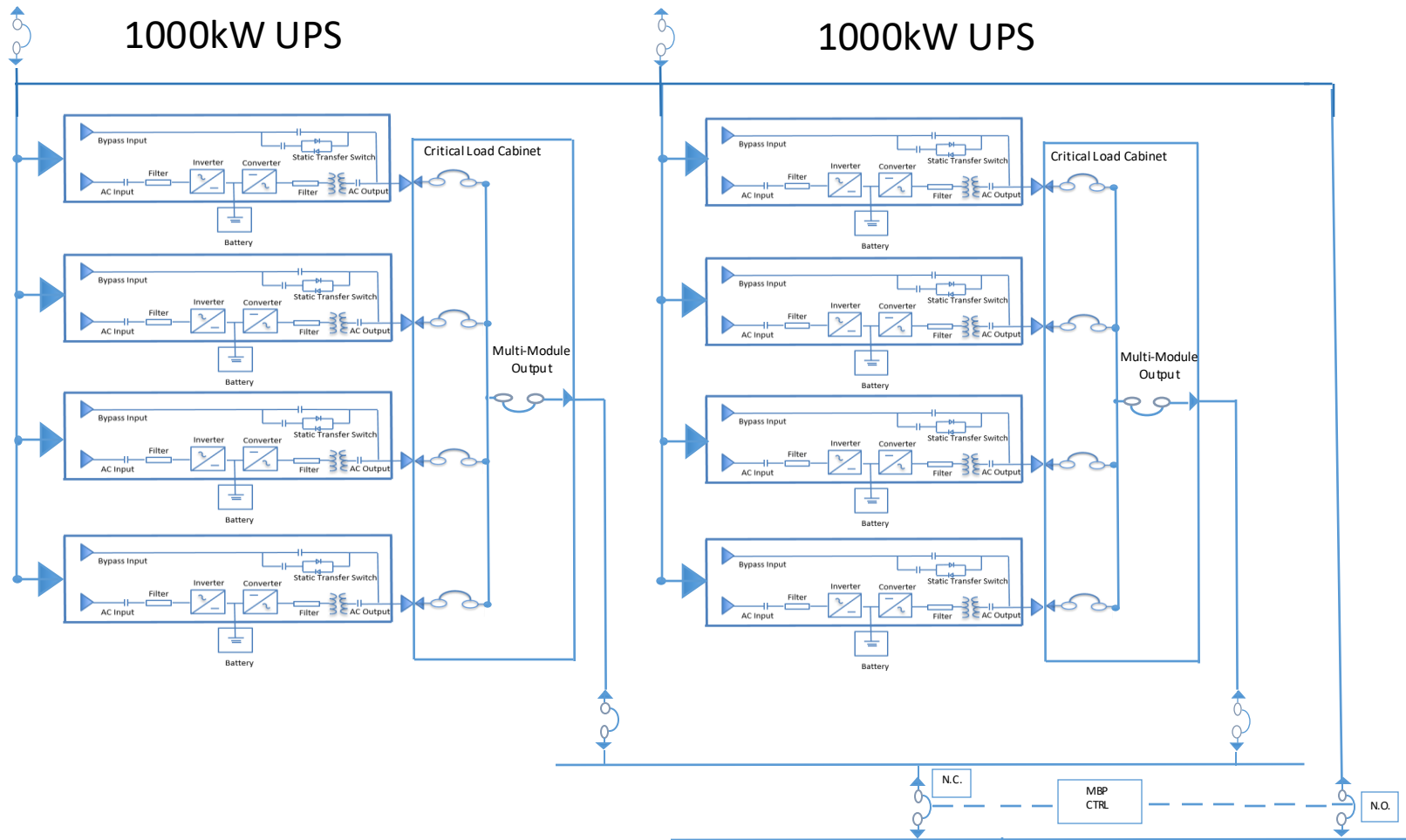

Feeder Breakers	2
Internal Feeder Breakers	16
Isolation Input Breakers	8
Input Filter	8
Rectifier IGBTs	24
Inverter IGBTs	24
Output Filters	8
Isolation Output Breakers	8
Static Switches	8
Bypass Breaker/Contactors	16
Output Breakers	8
Main Output Breaker	2
	140

And remember 100's of capacitors & dozens of fans

UPS Cost of Ownership

UPS Reliability and Availability

Rotary UPS (EC) Rating – 2MW



PILLER
Power Systems

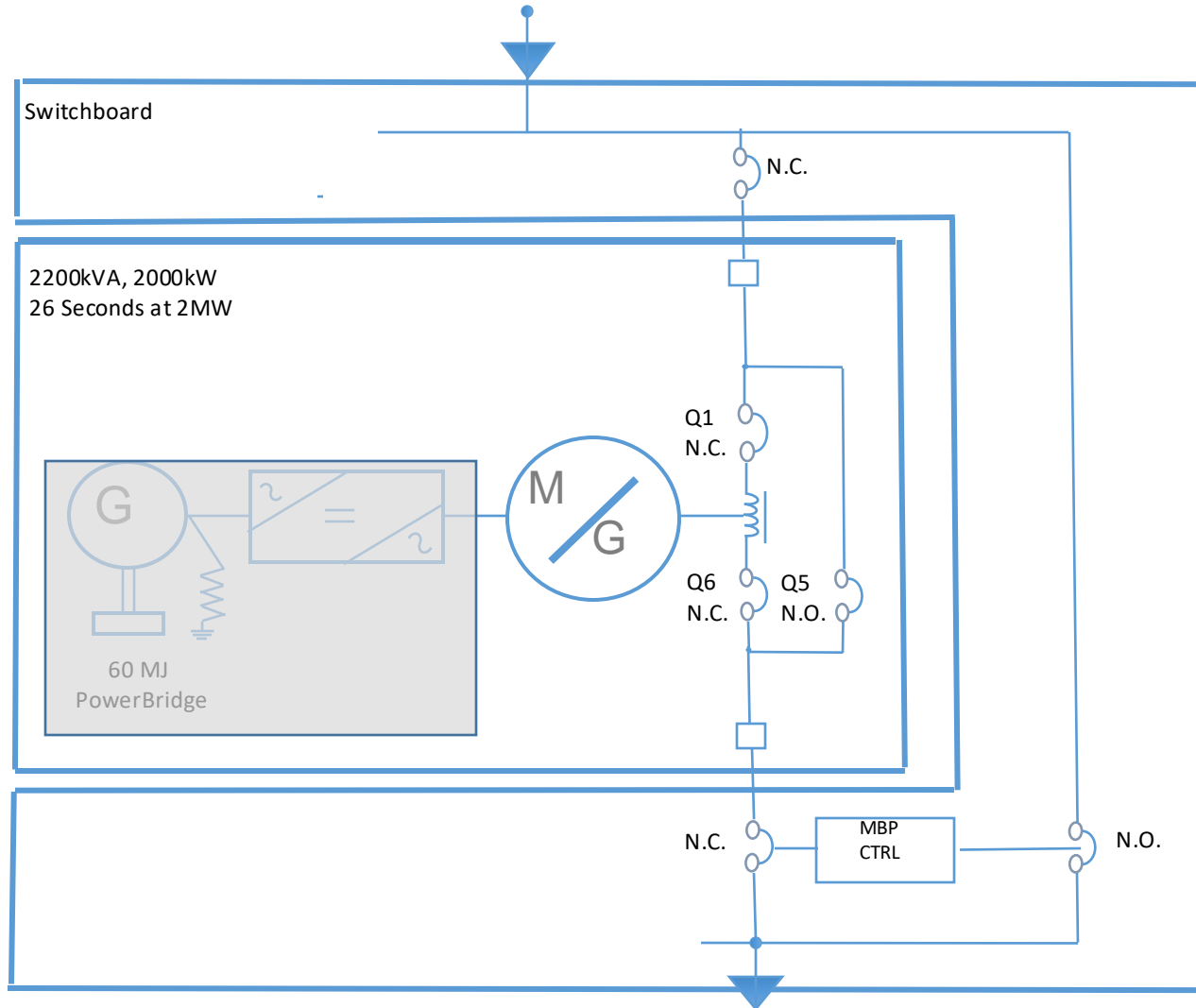

Feeder Breakers	1
Isolation Input Breakers	1
Input Filter	NA
M/G - (Rectifier IGBTs)	1
M/G – (Inverter IGBTs)	incl.
Choke	1
Isolation Output Breakers	1
Static Switches	0
Bypass Breaker/Contactors	1
Isolation Output Breakers	1
Main Output Breakers	<u>1</u>
	8

UPS Cost of Ownership

UPS Reliability and Availability Review



MTBF

- ❑ MTBF is not related to lifetime
- ❑ MTBF traditional Static UPS 587,450 h (n+1 modules)
- ❑ MTBF UB-V UPS system 3,086,620 h

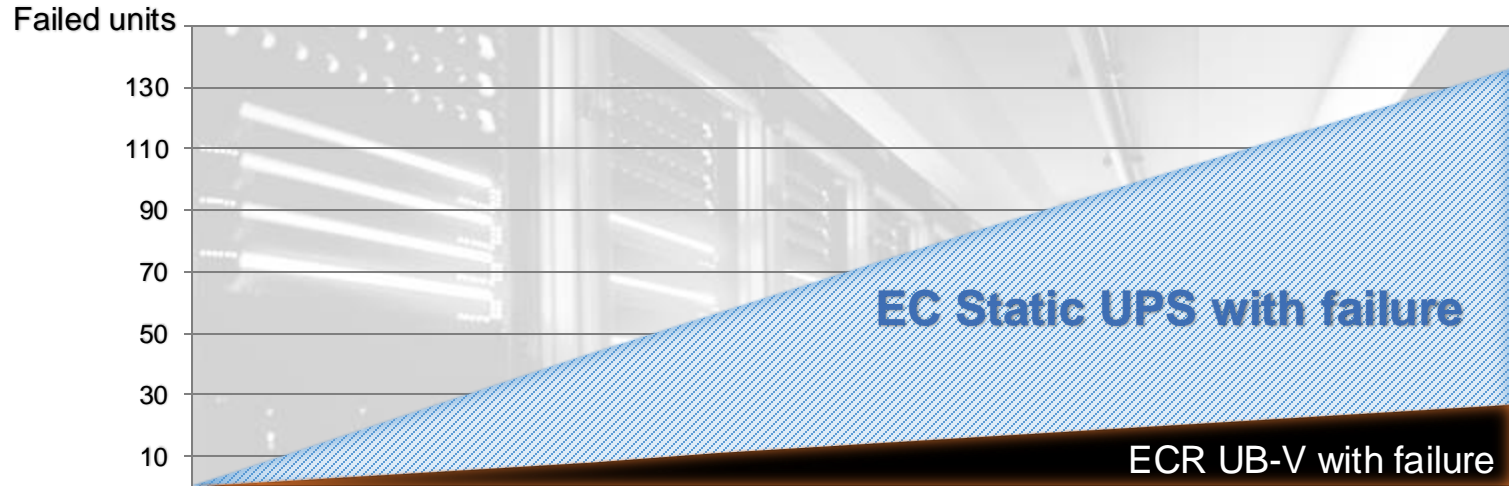

$N(0) = 1000$	Year	1	2	3	4	5	6	7	8	9	10
	Hours	8,760	17,520	26,20	35,040	43,800	52,560	61,320	70,080	78,840	87,600
EC static UPS with failure		14.8	29,4	43,7	57,9	71,8	85,6	99,1	112,5	125,6	138,5
ECR UB-V with failure		2.8	5,7	8,5	11,3	14,1	16,9	19,7	22,4	25,2	28,0

Failure rate = $\lambda = 1/\text{MTBF}$

Number of working units after time t:
 $N(t) = N(0) \times e^{-(\lambda \times t)}$

In a 10-year time period the likelihood for a failure is **5 times** higher for EC static UPS compared to the Rotary UPS

2024 FHEA FALL EXPO TALK



TRAINING

Summary

Campus wide UPS deployment

Summary

- ❑ Technology and Topology – Impact CAPEX and OPEX
 - ❑ MV deployment
- ❑ Footprint – Impact CAPEX and OPEX
 - ❑ Room requirements
 - ❑ Battery vs Flywheel
- ❑ Efficiency – Impact OPEX
 - ❑ How efficient is are the technologies
- ❑ Maintenance – Downtime – Impact OPEX
- ❑ Reliability and Availability – Impact OPEX

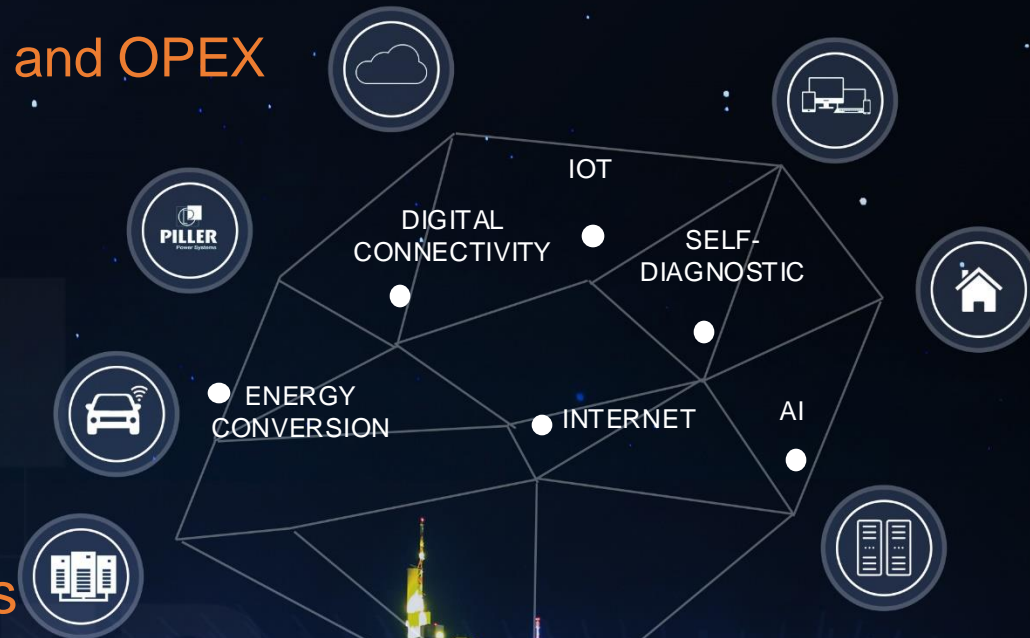

Other considerations for MV deployment

- Cut power losses – increase efficiency, improve OPEX
- Reduce Real Estate./Material – reduce CAPEX
- Reduce Energy by reducing mutual heating
- Practical LV deployment limitations – breaker size, cable size.
- LV UPS deployment – more equipment, more infrastructure and more cost.

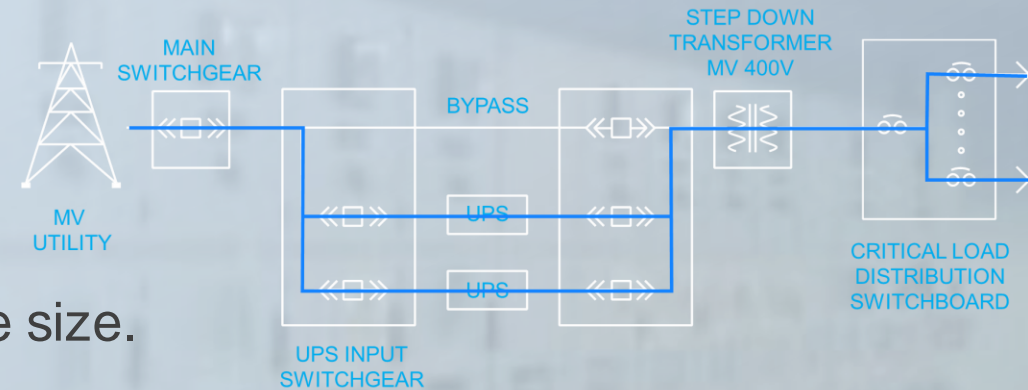

Another ADVANTAGE.....

- MV rotary UPS typically utilizes a 25+year design criteria which compliments MV switchgear deployment that is also designed with the same criteria under ANSI design guidelines.
- *“This means the UPS is designed for the life of the MV system. Static UPS is limited to 10–12-year design standard”*

2024 FHEA FALL EXPO TALK



Thank you!

Mike Sheppard

Regional Sales Manager

Piller Power Systems Inc

Michael.Sheppard@piller.com

Phone 312-802-1187