



WELCOME TO OUR FHEA PRESENTATION

What happens the day after the open house?
**Implementing an Equipment Management Strategy at
Master Planning.**

AIA course number PHC2022EMSMP

1 hour AIA CEU credit
1 hour EDAC CHD credit





About My Background

My Name is Gary Schindele



- **Current Executive Board Member, Past Board Chair and a Fellow of the Health Facility Institute (HFI)**
- **Served on two Facility Guideline Institute (FGI) subcommittees developing new standards for Emergency Conditions and Surge**
- **Have been involved in hundreds of healthcare facility projects around the world for 40 years**
- **48 years as a certified EMT Firefighter and former Paramedic**
- **Active member in the Central Florida Disaster Medical Coalition Team**



AIA/EDAC Learning Objectives

At the end of this program, participants will be able to:

1. Identify and understand how to avoid repetitive and wasteful design errors and optimize the “point of care” after occupying the facility.
2. Explain how to develop, design and provide a life-cycle cost reduction solution to clients incorporating a flexible equipment management system into the basis of design.
3. Identify key areas of patient perception that impact HCHAPS scores and hospital reimbursement rates and how to provide a system to regain patient trust in Healthcare delivery.
4. Provide end-users with the means to grow, change, and adapt to their future needs without compromising the integrity of the facility or your design intent, and to adapt to “immediate demand” for surge beds.
5. Support through design and planning, rapidly deployable solutions to manage surge populations and respond to emergency crisis situations as they relate to the new FGI Emergency Conditions Guidelines.

Without the proper tools to **manage healthcare environments**, clinical staff and facilities teams are left to **deal** with them, and that generally results in compromises at every level.

Whenever you **“DEAL”** with something, you are generally reactive and in **at the mercy of the event or environment.**



An Equipment Management Strategy provides Owners, Managers, and Clinical Teams the difference between “Dealing with” vs. “Managing” a patient care environment on “Day 2” after open hose.

When you “MANAGE” something, you are generally in a pro-active decision mode and in control of the event or environment.





What should our “WHY” be?

Why are we designing a healthcare environment in the first place?

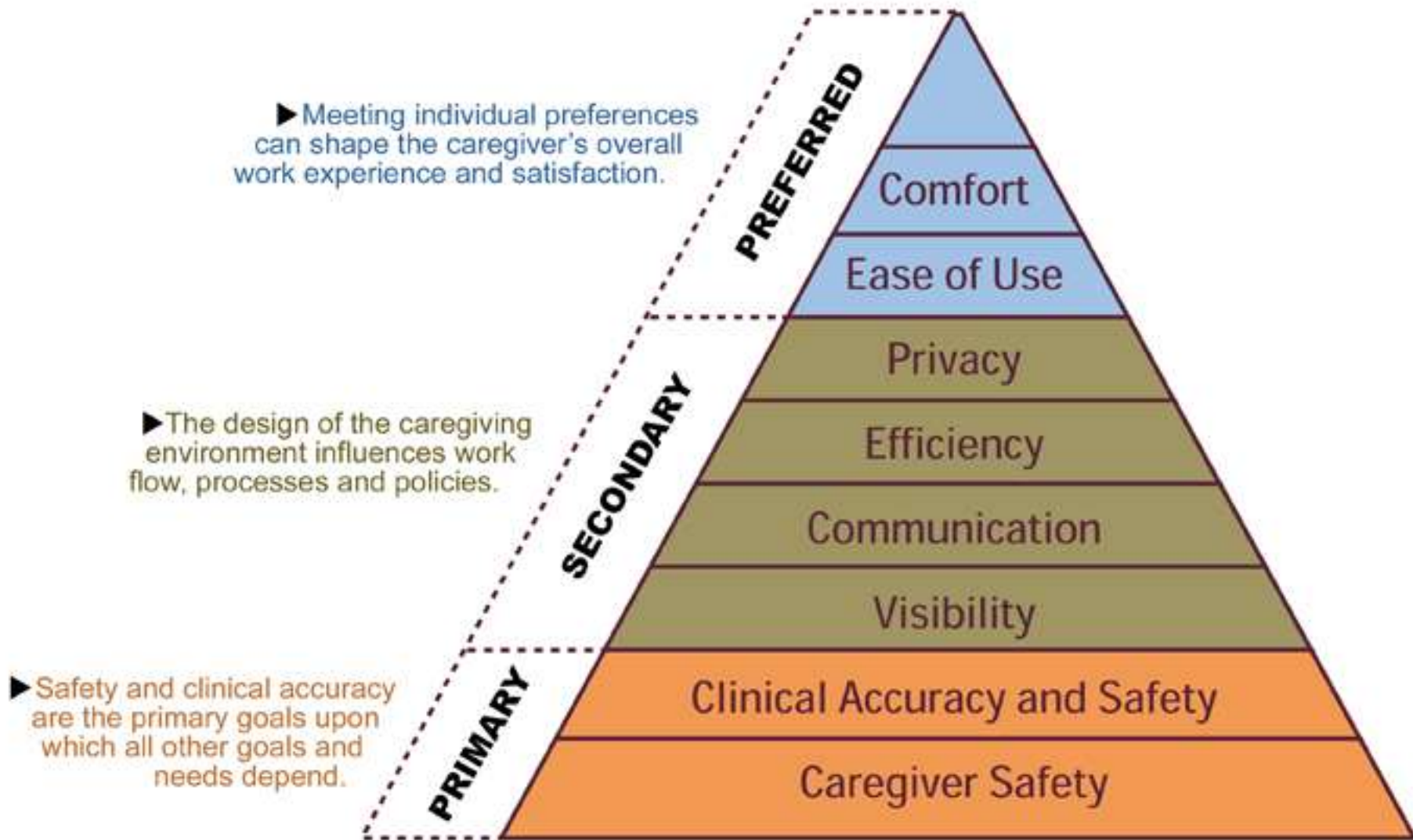



What is the Clinical “WHY”?

KEEPING PACE

The design sector needs to stay focused on patient and clinical needs while adapting to technology and science advancements impacting the healthcare landscape

By Debra Levin in the September 2023 issue of Healthcare Design Magazine

“Of course, the types and extent of specific design changes will depend on the pace of technological progress, regulatory frameworks, and the priorities of healthcare organizations. In the end, though, the ultimate goals for quality healthcare design will not change: creating environments that optimize patient care, support healthcare providers, and adapt to emerging trends and innovations in the healthcare industry”.

Debra Levin is president and CEO of The Center for Health Design.



What is the Owner's "WHY" ?

Most common client goal for projects in 2019

Improving patient experience / satisfaction

40%

Designing spaces for future
Flexibility / Adaptability

35%

Supporting population health /
Creating ambulatory networks

18%

Addressing aging building stock

5%

Rebranding

2%

From: Guiding Principles for the Development of the Hospital of the Future published by The Joint Commission

- “The lengthy cycle of design and construction is often overtaken by the rapid cycle of innovation in medicine and technology. As a result, some buildings are partially obsolete when they open, and nearly every health care structure will be obsolete in some way before it has completed its useful life. **Design for flexibility is a way to reduce the inconvenience and cost of these inevitable disruptions.**”

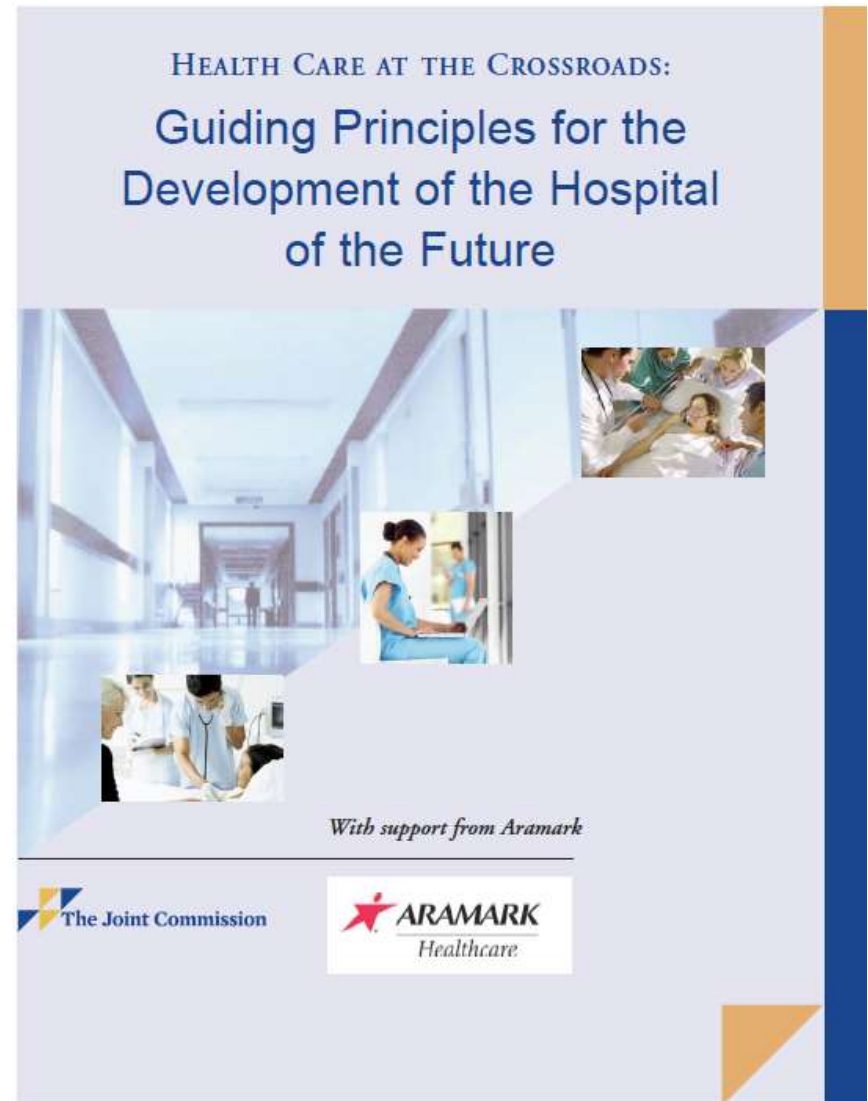



**So, what happens to the pretty hospital
the day after open house,
and what can we do
to “manage” clinical reality?**

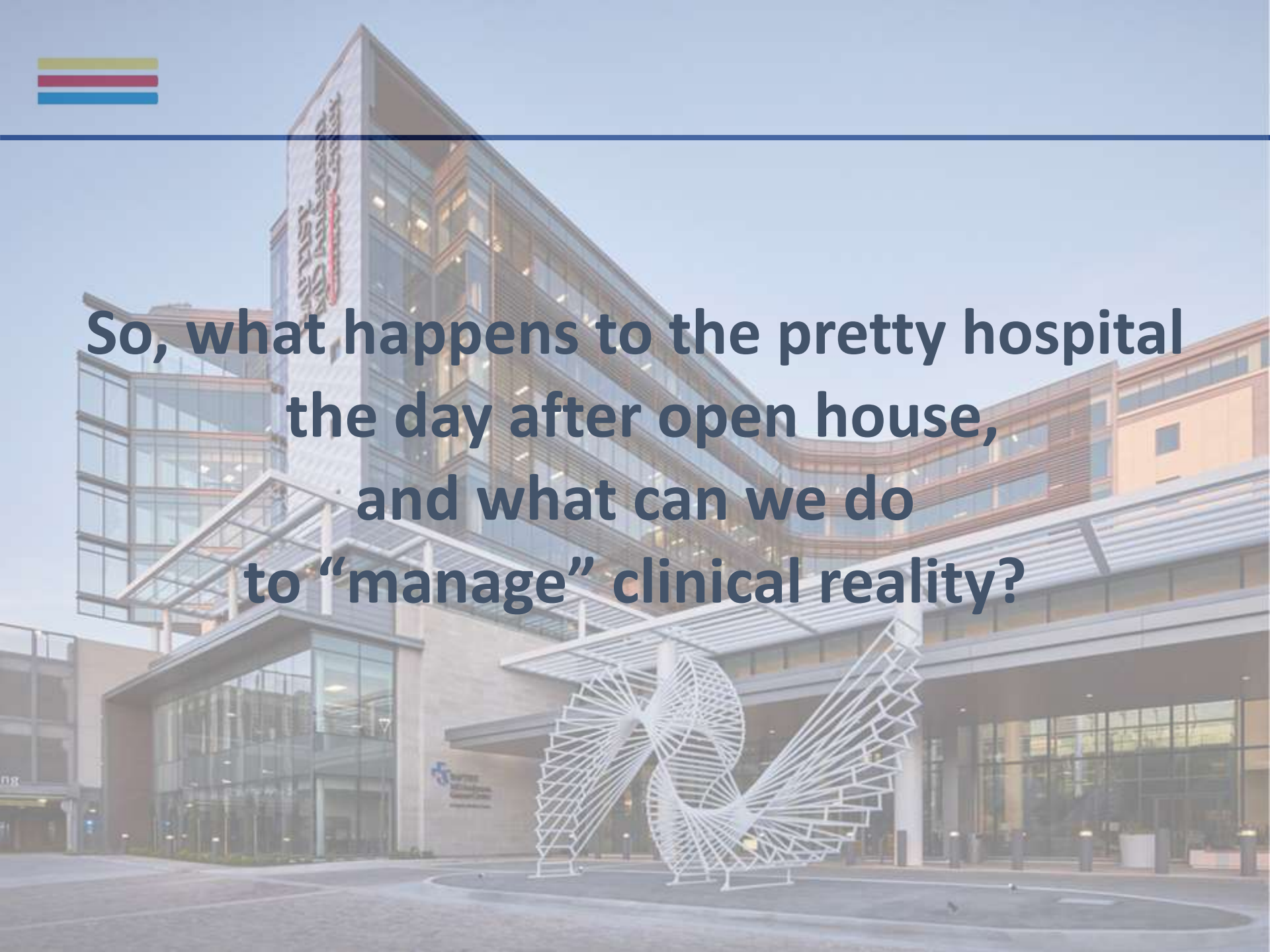



Reality check!

In the end..... our collective designs serve the most challenging environments in healthcare.

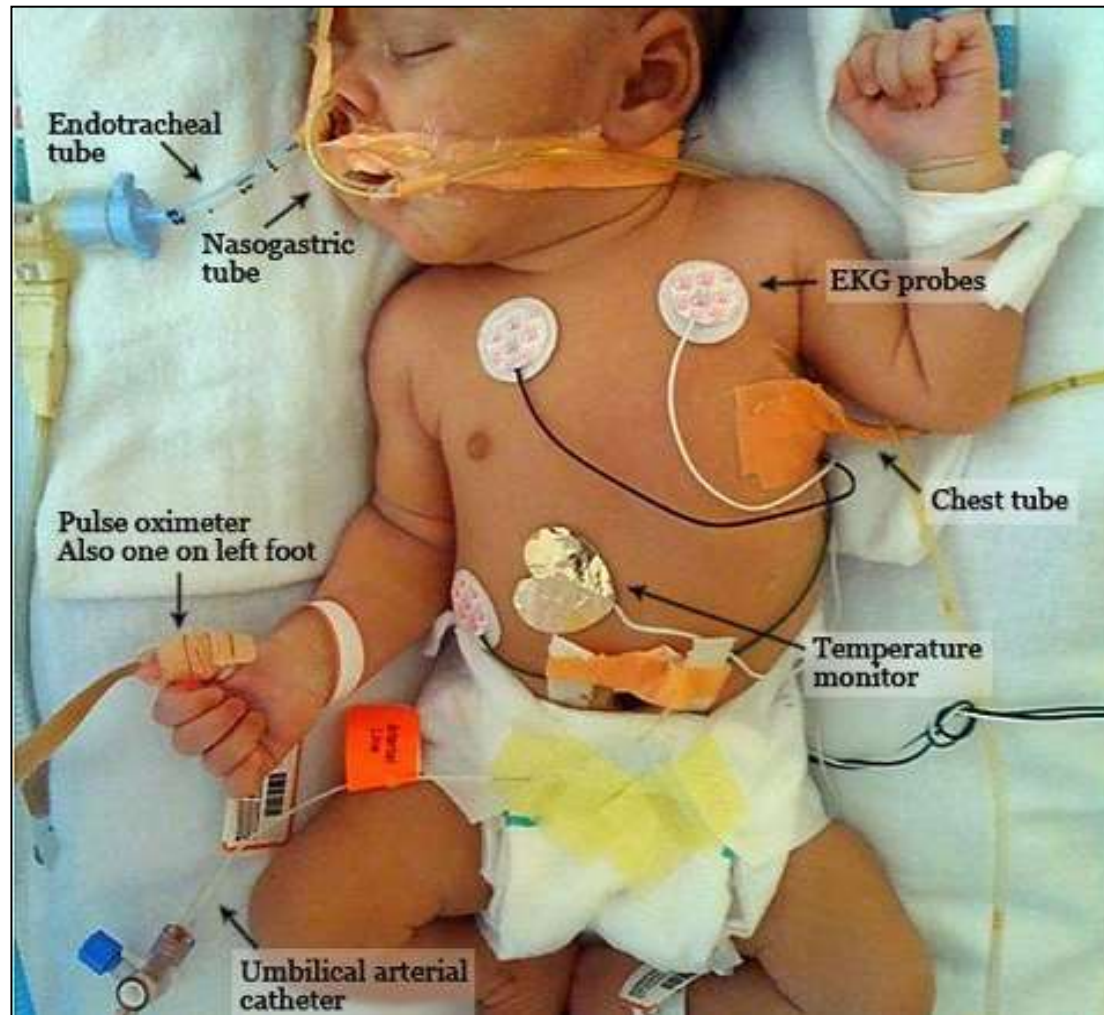

Everything identified in this picture is connected to “something.”



...and the “somethings” usually amount to a collection of dissimilar devices like these.

This is what the current state of modern medicine looks like right now.



With that in mind . . .

We have
Good news,

and we have
Bad news!



THE GOOD NEWS



AFTER A
CONSTRUCTION
OR RENOVATION
PROJECT

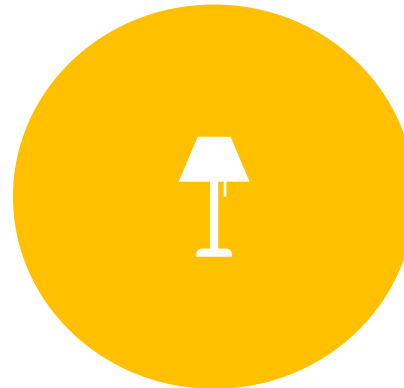

YOUR CLIENT WILL
MOVE INTO A NEW
ENVIRONMENT
THAT HAS NEW
CARPETING, NEW
LIGHTING



NEW FURNITURE
AND NEW
FINISHES, ETC.



“Utopia General Hospital,” aka, the “Perfect Healing Environment.”
This is the goal of every design professional.



Then after open house, the bad news sets in
and comes in a form of a question...

Is there a **hose, tube, cable or wire** that is going
to go away just because patients are moving
into a new facility?

This is what the previous pictured room actually looks like post occupancy.



Form

Needs to follow

Function





In reality, a patient room is nothing more than a “dysfunctional application of dissimilar technologies”

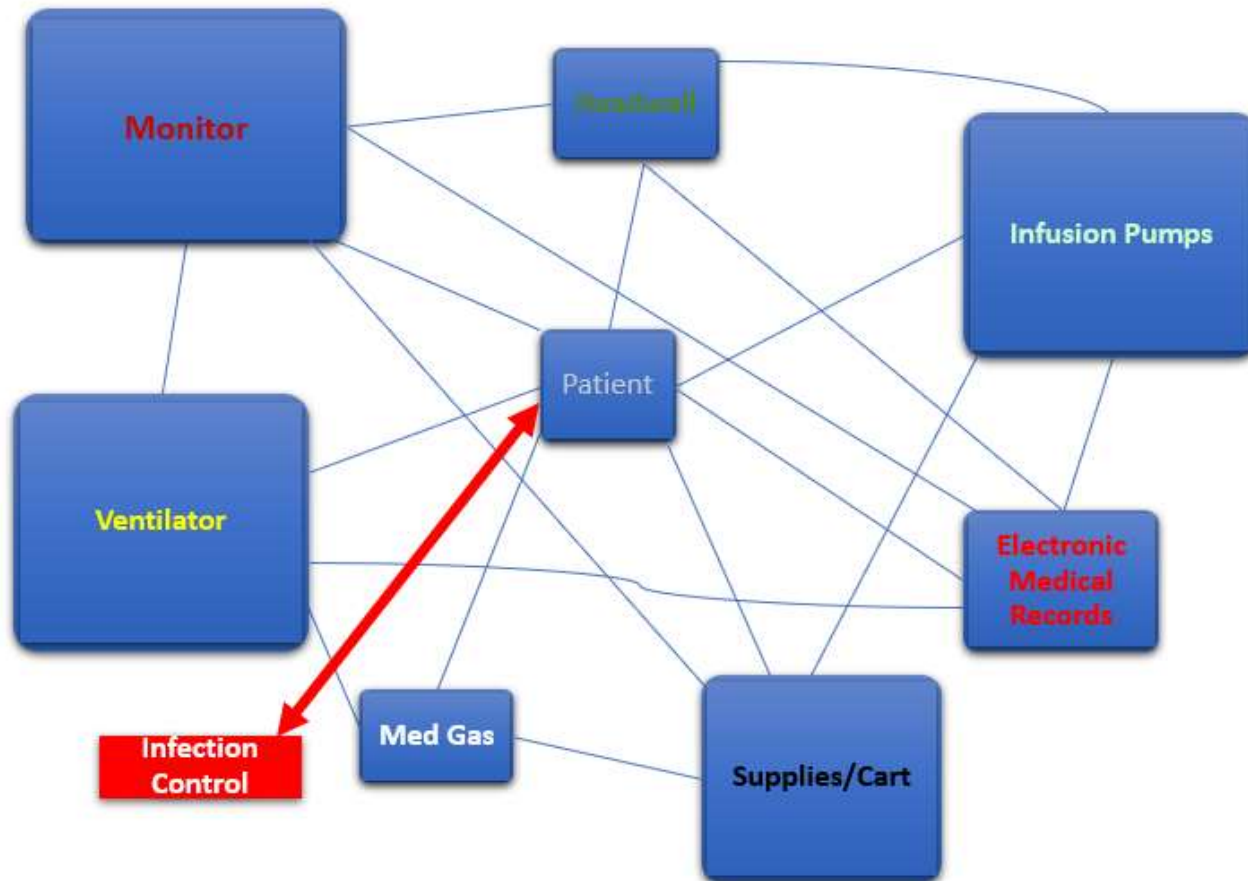

Traditional integration of medical equipment fosters chaos!



When you look at them all individually, you can better understand the dysfunction of the environment.



CHAOS = Clinicians
Have Arrived On Site



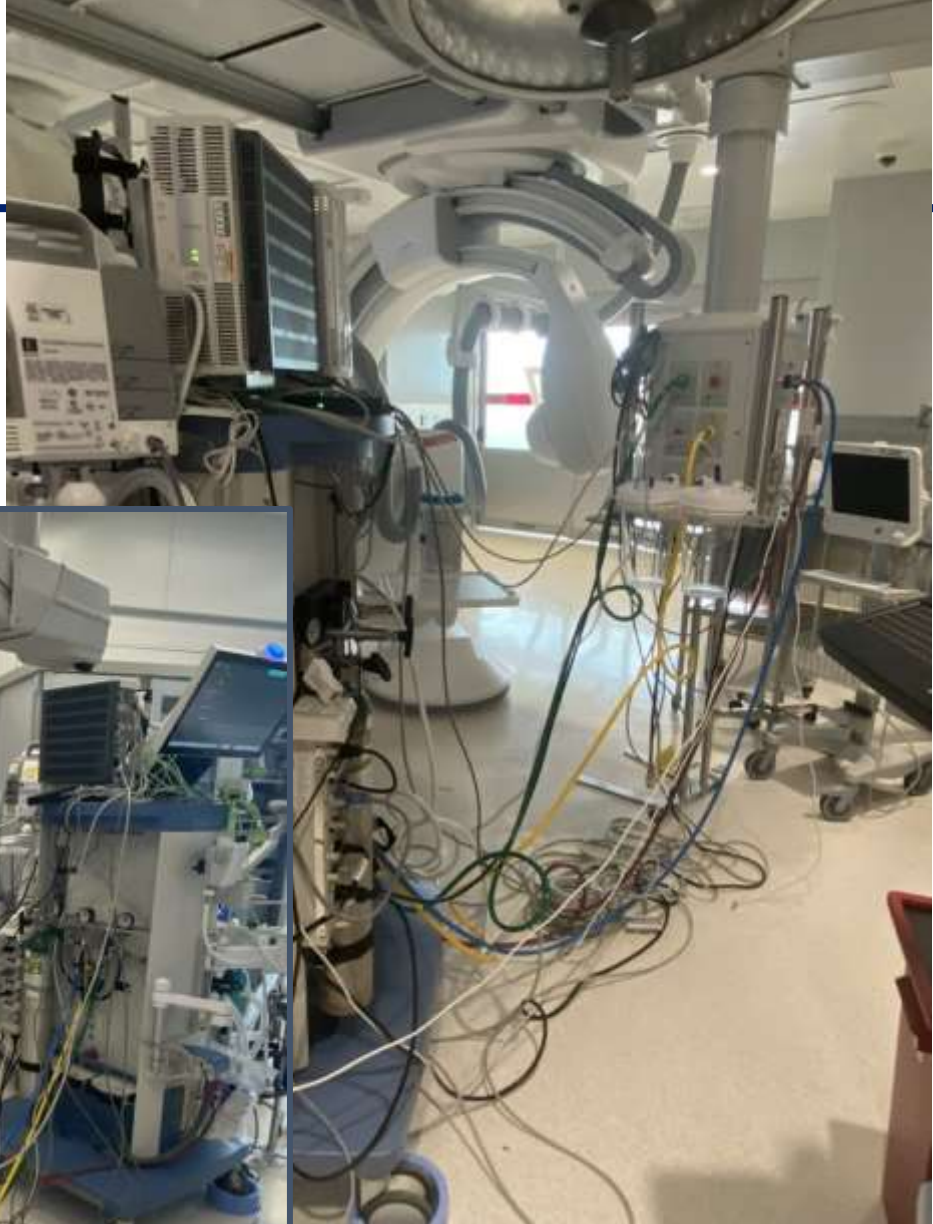

“State of the art” new facility, opened fall of 2021.....one month post occupancy.



Post occupancy is when oversights, installation mistakes, changed needs and vendor errors are discovered causing conflicts.





THERE IS NO PERFECT OR STATIC PATIENT ROOM!

Patient treatment requires devices, technology, hoses, tubes, and cables; all of which change per patient. Not planning for that does our clients a major disservice.



Flexibility of spaces

For hospitals in 2023 and beyond, the **flexibility of spaces** will remain a constant in design. Not only are flexible spaces essential when the next pandemic or natural disaster occurs and facilities need to **adapt and mobilize** to meet short-term needs, but they are also necessary due to the fast rate at which technology is advancing. As the healthcare sector continues to evolve, **designing flexible spaces** does more than just prepare hospitals for crises, it increases the utilization of a facility by providing more options to **adapt in unforeseen situations**.

For example, **acuity-adaptable patient rooms** — hospital rooms that allow care to come to the patient rather than moving the patient to where care is — are becoming more predominant. **Acuity-adaptable patient rooms help solve the issue of overcrowding** within hospitals, while ensuring the patient is cared for in the same room no matter their care needs. In pandemic-specific situations, a **flexible solution** that will rise in popularity will be the use of patient units that can be fully exhausted in the event that an isolation unit is needed. For instance, emergency department observation units that can be fully exhausted and **mobilized as additional treatment areas** provide the dual purpose of serving as an ED and substitute trauma unit when needed. **Flexibility in design** can be carried into other areas of hospitals, such as ambulance bays that transform into mass decontamination zones and education spaces that shift to become emergency triage when the need arises.

Adaptability, convertibility and flexibility of healthcare spaces will be more important than ever, cementing a standard across the industry as a way to care for patients and support caregivers in an efficient and effective manner.



The implementation of an Equipment Management Strategy defines and creates the ideal flexible, adaptable and expandable healthcare environment at many different levels.

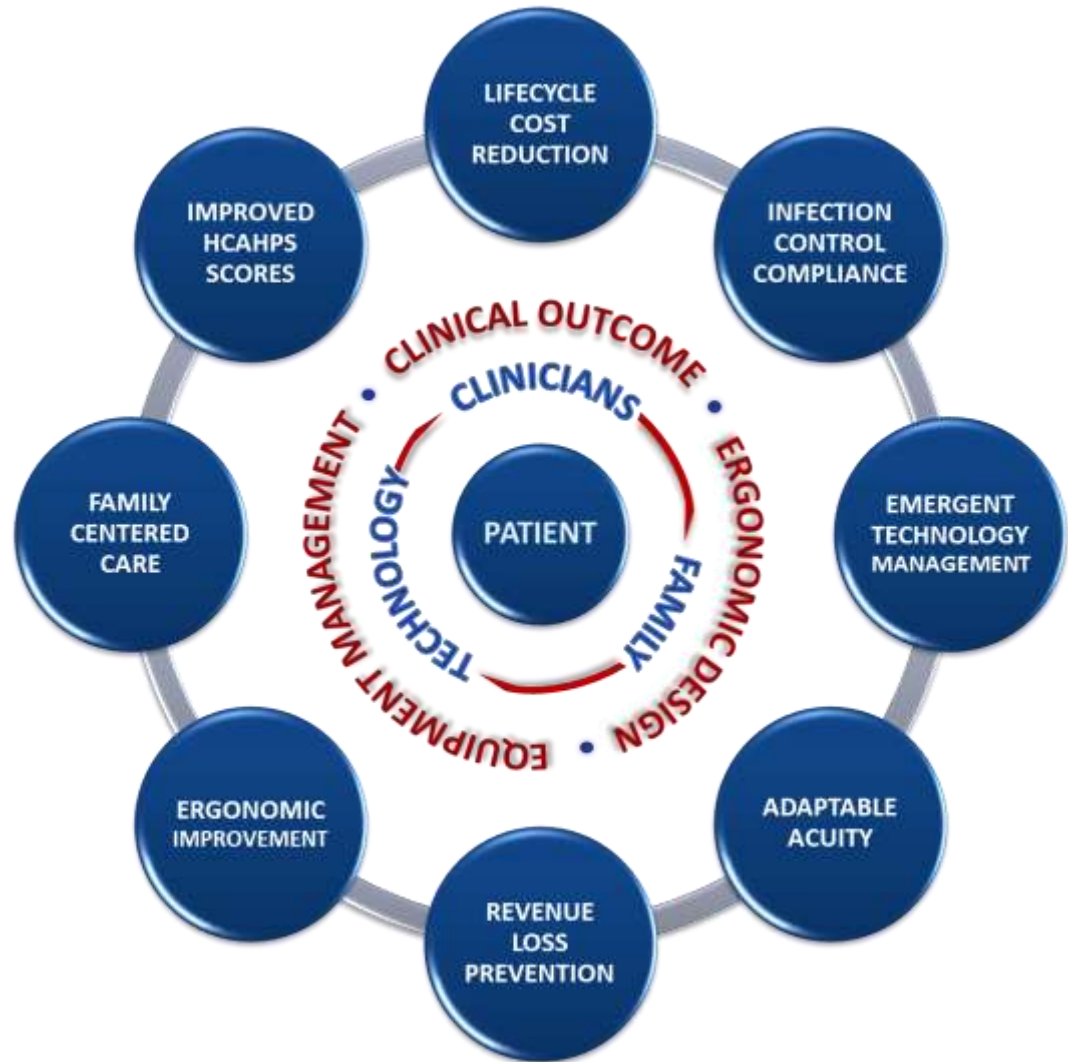



We often look to “VALUE ENGINEERING” when budgets are tight.

Value Engineering (VE) is NEITHER a design/peer review, nor a cost-cutting exercise.



Value Engineering as defined by:

“a creative, organized effort, which analyzes the requirements of a project for the **purpose of achieving the essential functions at the lowest total costs** (capital, staffing, energy, maintenance) **over the life of the project.**”

“Through a group investigation, using experienced, multi-disciplinary teams, value and economy are improved through the study of alternate design concepts, materials, and methods **without compromising the functional and value objectives of the client.**”



FIRST COST VERSUS LIFE-CYCLE COST

AN EQUIPMENT
MANAGEMENT
STRATEGY IS THE
INSURANCE POLICY
FOR YOUR PROJECT
AND FOR THE OWNER!



**IT IS PAID FOR
UP-FRONT**

**HOPE WE
NEVER
NEED IT**

**..BUT GLAD
WE HAVE IT
WHEN WE DO**



An Equipment Management Systems will
GUARD AGAINST INEVITABLE CHANGES AND ASSOCIATED COST
requested by the clinical teams post occupancy

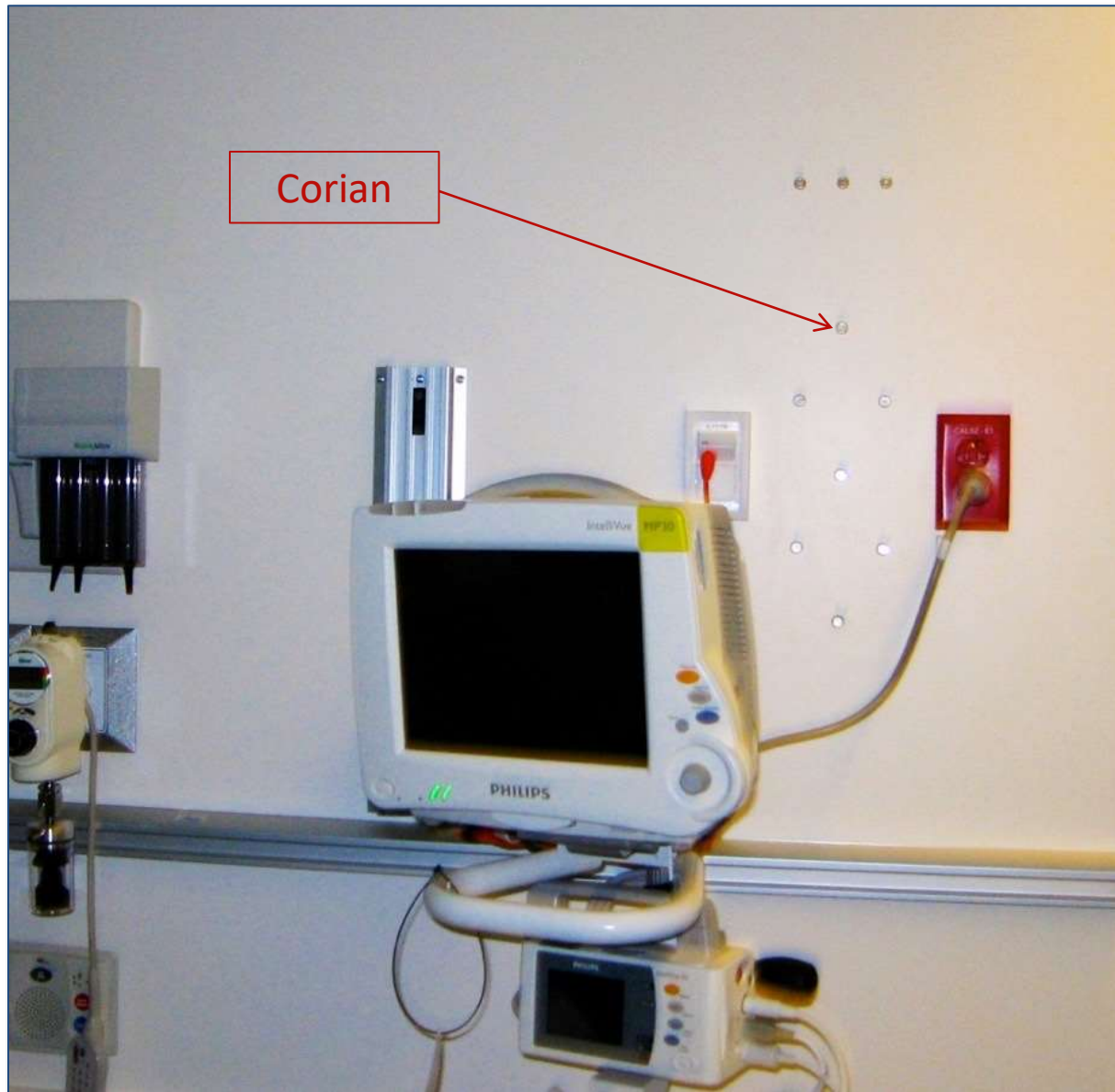



.....and guard against poor design.

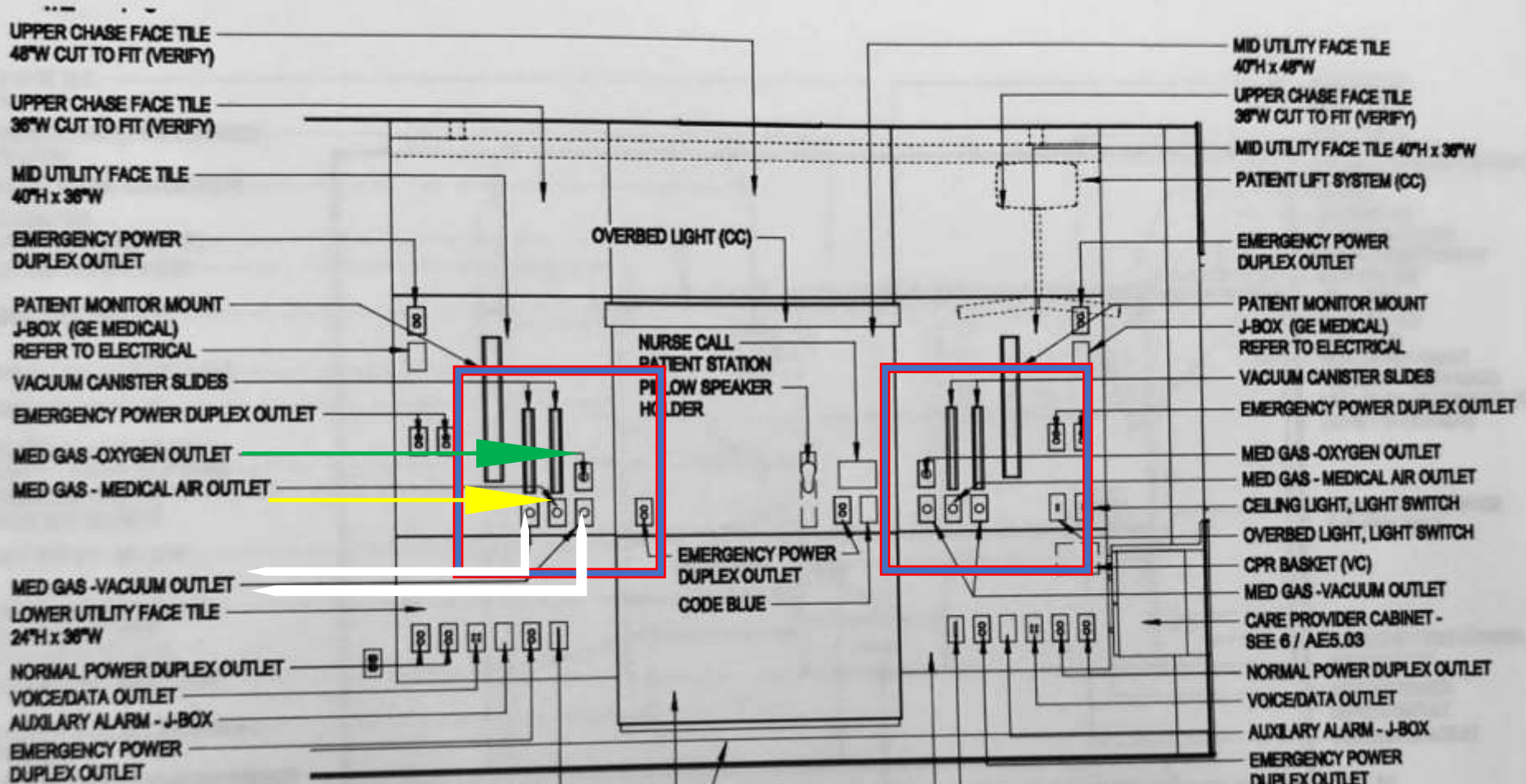

Yes, this will pass inspection, but will immediately force users to DEAL with a very poor layout.



Best intentions, but no POE reality taken in to consideration.



Note the 3 duplex emergency receptacles blocked and rendered useless by the poor planning and placement of the rail and clinical supplies.

No “real world” post occupancy spatial planning taken in to consideration during design.





The by-product of change usually comes in the form of unnecessary wall damage and COST to your facility!





Organization drives perception. Perception drives reality!

March 2016: Improving the Patient Experience Through the Health Care Physical Environment

“**The perception of cleanliness** also is affected by the physical environment. The perception of clutter—even when environments are clean—can lead to lower patient satisfaction scores.”

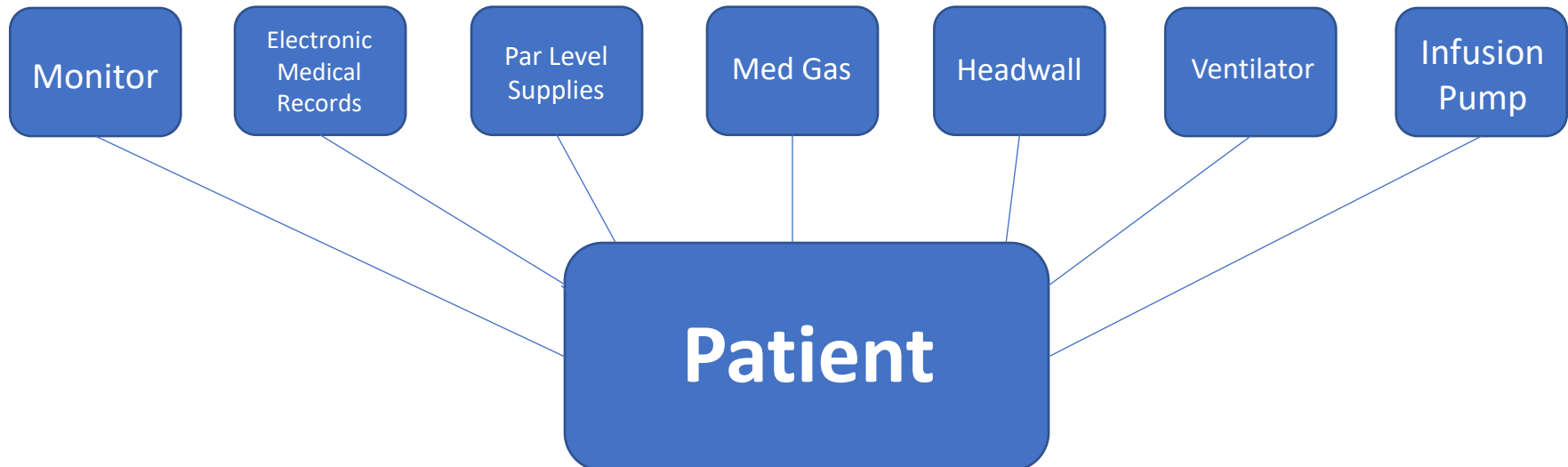

If you think patients
are not paying
attention,
Think again.....

Actual quote from a
chemo patient's
responding HCAHP
Survey:

If you can't fix a
simple hole in the
wall, how can I
expect you to fix
me?





UPFRONT

ENVIRONMENTAL SERVICES

Perceptions of cleanliness could cost hospitals

Patients who perceive hospital cleanliness in a negative light often do more than give low scores on HCAHPS surveys. Many assume that they are at greater risk of acquiring a health care-associated infection (HAI) during their stay and will not recommend the hospital to others. Moreover, new research suggests that their suspicions are often correct.

These are a few key findings in new research from Press Ganey and Compass One Healthcare. The firms also say that results of an analysis of HCAHPS patient experience of care metrics and the incidence of specific HAIs reported to the Centers for Medicare & Medicaid Services

for the year ending June 30, 2014, show a relationship between patients' perceptions of cleanliness and HAIs.

... The data show a clear correlation between patients' perceptions of cleanliness as measured by the HCAHPS question "How often were your room and bathroom kept clean?" and the incidence of methicillin-resistant *Staphylococcus aureus* and *Clostridium difficile*," the report states. "Hospitals that scored in the highest quintile for cleanliness had, on average, the lowest number of reported infections."

As for what environmental services (ES) teams can do to improve patient perceptions about cleanliness, the report recommends:

- ES staff should understand, communicate and take pride in the important role perceptions play in patient safety and clinical quality improvement efforts.
- Consistently assess and improve cleaning methods and procedures to ensure a pathogen-free environment and

prevent the transmission of bacteria, viruses and other infection sources.

- Continually audit practices that measure the cleanliness of high-touch surfaces.
- Promote staff accountability for cleanliness and encourage self-audit procedures.



The report also notes that because ES technicians often are dispersed geographically throughout a facility, these workers can feel isolated from their departmental colleagues. Hospital leadership and ES managers can help teams to overcome this challenge through best practices such as:

- Making sure ES technicians are recognized as important members of the department or unit where they clean.
- Involving the ES staff in regular departmental meetings, including huddles at the start of every shift, training and development sessions, and monthly staff meetings.
- Encouraging frequent rounding and observation by ES managers. // BY BOB KENDE

This Dec. 2016 article in Health Facility Magazine also highlights the relationship between the “perception of cleanliness” and HAI’s.

“Patients who perceive hospital cleanliness in a negative light often do more than give low scores on HCAHP surveys. Many assume that they are at greater risk of acquiring a health care-associated infection (HAI) during their stay and will not recommend the hospital to others. Moreover, new research suggests that their suspicions are often correct.”

These are a few key findings in new research from Press-Ganey and Compass One Healthcare

MAKING DECISIONS JUST GOT EASIER.

We understand your need for hospital and health care data. AHA Data can help you quickly and easily find that data. Simply access information on about 6,300 hospitals and 400+ healthcare systems. Selecting data, creating reports and gathering insights has never been easier.

<http://info.healthforum.com/esourcevideo> | PHONE: 866-375-3633

American Hospital Association
HEALTH FORUM
 MEDIA • EDUCATION • DATA

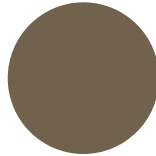
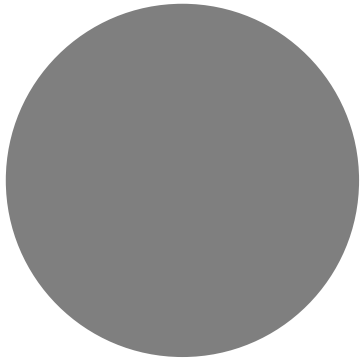

Organized, flexible, adaptable and expandable environments support healthcare providers as they strive to improve their HCAHPS scores.
(Hospital Consumer Assessment of Healthcare Providers and Systems)





**PLEASE DISINFECT
YOUR CELL PHONES
AND TABLETS BEFORE
GOING TO THE
BEDSIDE !!!
THANK YOU**

How can design make an impact on infection control mandates why should it be a key step in support of clinical reality?



TERMINAL CLEANING

HOW DO WE DEFINE
TERMINAL CLEANING IN A
POST COVID-19 WORLD?



What is the Track Record on Handwashing in Healthcare Facilities?

- A review of 34 published studies of handwashing adherence among healthcare workers found that adherence rates varied from 5% to 81%
- The average adherence rate was only 40%

Average Handwashing Adherence of Personnel in 34 Studies

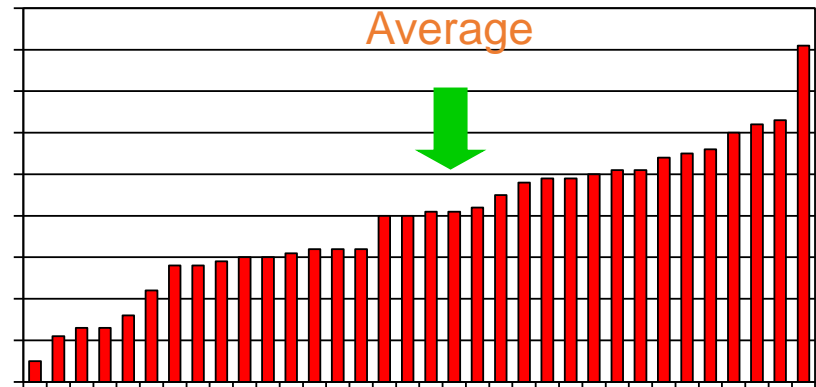

Published in the University of North Carolina Hand Hygiene Compliance Program Overview



What is “The WHY” driving Post-Covid related work

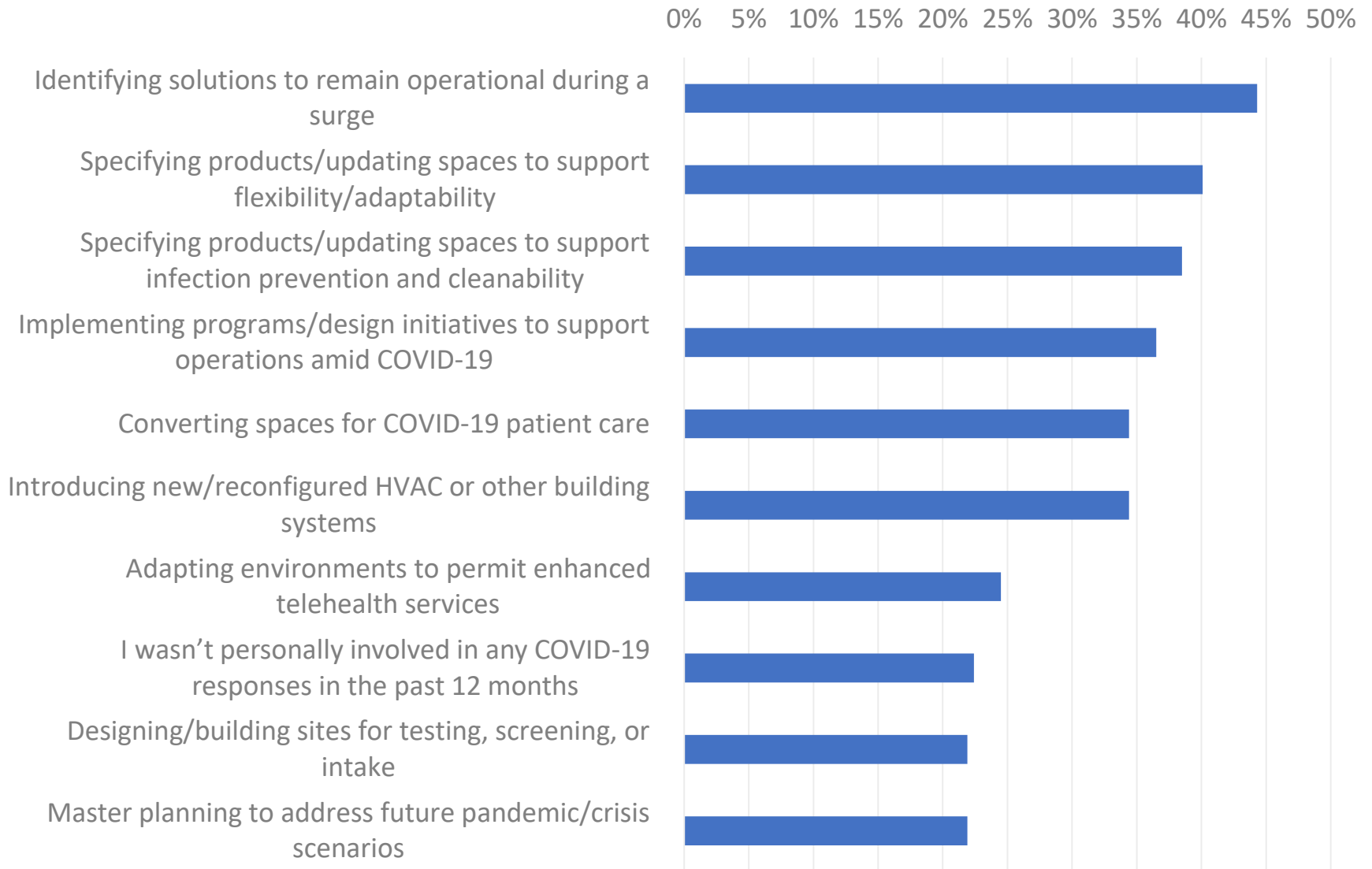



FACTS & FIGURES

Source MCD Medical Construction & Design, Volume 15, Issue 6, November/December 2019

100K

In the U.S., HAIs account for more than **100,000 deaths per year.** — nist.gov

\$161K

Average estimated annual **cost for an infection prevention program per hospital.** — ncbi.nlm.nih.gov

30%

Effective infection prevention and control reduces healthcare-associated infections by at least 30%. — World Health Organization

\$96-147B

Nationwide, HAIs increase medical **costs annually by around \$96-147 billion.** — nist.gov

50%

of surgical site infections can be antibiotic-resistant. — World Health Organization

19.2

An HAI adds **19.2 hospital days and \$43,000 in treatment costs for an average patient who develops an infection.** — cdc.gov

1 in 10

patients, globally, will get an infection while receiving care. — World Health Organization

15-20

seconds of vigorous hand-washing with soap and water is recommended to effectively kill germs. — cdc.gov

1 in 25

of U.S. hospital patients, are infected with HAI's per year. — nist.gov

35% +

Ultraviolet-C antimicrobial devices reduce the incidence of many HAIs by 35% or more. — nist.gov



SEPSIS

Causes

While any type of infection — bacterial, viral or fungal — can lead to sepsis, the most likely varieties include: Pneumonia, Abdominal infection, Kidney infection, Bloodstream infection (bacteremia)

Risk factors

Sepsis is more common and more dangerous if you:

- Are very young or very old
- Have a compromised immune system
- Are already very sick, often in a hospital's intensive care unit
- Have wounds or injuries, such as burns
- Have invasive devices, such as intravenous catheters or breathing tubes

\$17 Billion spent annually on Sepsis treatment in the United States

590 Sepsis deaths reported in the United States EACH DAY!

This data 2018



Center for Transforming Healthcare launches new Reducing Sepsis Mortality TST®

The Joint Commission Center for Transforming Healthcare has unveiled a Reducing Sepsis Mortality Targeted Solutions Tool® (TST®), a web-based application to help providers reduce sepsis mortality and increase sepsis protocol compliance in pursuit of zero harm.

Sepsis — a severe reaction in response to an infection — is a top cause of death in hospitalized patients that costs the health care system at least **\$41 billion each year**. It typically affects 1.7 million U.S. patients yearly, with about **270,000 of those cases resulting in death**.

Early recognition and effective treatment of sepsis not only saves lives but also frees up scarce resources and dollars that hospitals need for staff or to rebuild services and infrastructure.

FOR PATIENTS AND FAMILIES

GET AHEAD OF SEPSIS

KNOW THE RISKS. SPOT THE SIGNS. ACT FAST.

HOW CAN I GET AHEAD OF SEPSIS?

As a patient, you can take specific steps to reduce your risk of sepsis, including caused by COVID-19, such as:

1 PREVENT INFECTIONS

Talk to your healthcare professional about steps you can take to prevent infections that can lead to sepsis.

 Take good care of chronic conditions	 Get recommended vaccines
---	---

2 PRACTICE GOOD HYGIENE

Remember to wash your hands and keep cuts clean and covered until healed.

 Wash your hands	 Keep cuts clean and covered until healed
--	---

3 KNOW THE SIGNS AND SYMPTOMS

A patient with sepsis might have more than one of the following signs or symptoms. A medical professional is needed to confirm sepsis.

 High fever or low blood pressure	 Pain or swelling, or feeling very weak	 Confusion or disorientation
 Rash	 Extreme pain or discomfort	 Chills or overly hot

4 ACT FAST

Sepsis is a medical emergency. ACT FAST.

To learn more about sepsis and how to prevent infections, visit www.cdc.gov/sepsis or call 1-800-CDC-INFO.

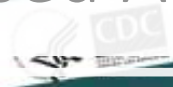

HOW CAN I GET AHEAD OF SEPSIS?

Steps to reduce your risk of sepsis, including COVID-19, such as:

PREVENT INFECTIONS

Talk to your healthcare professional about steps you can take to prevent infections that can lead to sepsis, including COVID-19. Since vaccinations prevent many infections, getting vaccinated can help prevent sepsis.

GOOD HYGIENE

Keep cuts clean and covered until healed.

KNOW THE SYMPTOMS

A medical professional is needed to confirm sepsis.

has a fever

and if

FOR PATIENTS AND FAMILIES

IT'S TIME TO TALK ABOUT SEPSIS.

Infections put you and your family at risk for a life-threatening condition called sepsis.

GET AHEAD OF SEPSIS

KNOW THE RISKS. SPOT THE SIGNS. ACT FAST.

CDC Released August 2023



Modern Healthcare



January 17, 2023

“Patients delaying care over cost reached an all-time high in 2022”: Survey

A record number of patients delayed medical care because of high costs last year, according to survey results Gallup published Tuesday.

Gallup found that **38% of respondents or a family member delayed treatment over costs in 2022, a 12 percentage point increase compared to 2020 and 2021.** The upswing coincided with economywide inflation reaching a 40-year high.

Last year's spike in delayed care was the largest over one year since Gallup first began tracking these data more than two decades ago. The previous high was 33% in 2014 and 2019, while an average of 29% of patients reported delayed care over costs from 2001 to 2021.

More than one-quarter of those who participated in the 2022 survey said the care they forewent **was for “very” or “somewhat” serious conditions**, while 11% went without care for non-serious conditions. Lower-income people, younger adults and women were among the groups more likely to delay care.



Candida auris Update: Information for Clinicians and Laboratorians
Version 10.0 June 20, 2023

This is an update to the Florida Department of Health (Department) detection and reporting guidance for multidrug-resistant Candida auris (C. auris). We are actively identifying cases throughout the state. **This important fungal pathogen can cause invasive infections, is drug-resistant, persists in the environment and is transmitted in health care settings.** Additionally, C. auris can be misidentified using standard laboratory methods.

Patients with C. auris bloodstream infections have a **30-day mortality rate of 39%**.

The Department, in collaboration with facilities, provides ongoing technical assistance for conducting surveillance, works with laboratories to ensure the use of proper C. auris detection methods and provides guidance to facilities for infection prevention including hand hygiene, environmental cleaning, and contact precaution strategies.

Let us also consider adopting better signage regarding hand sanitizing following the guidelines set by the **World Health Organization (WHO) in 2009**

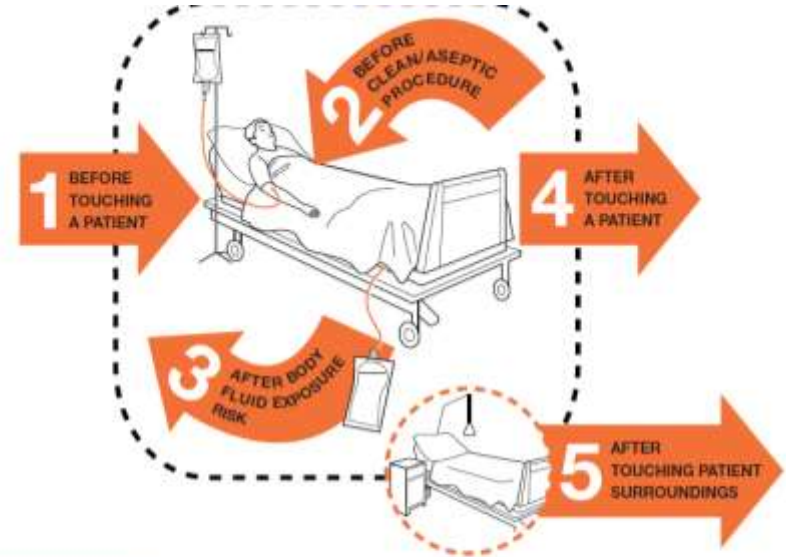
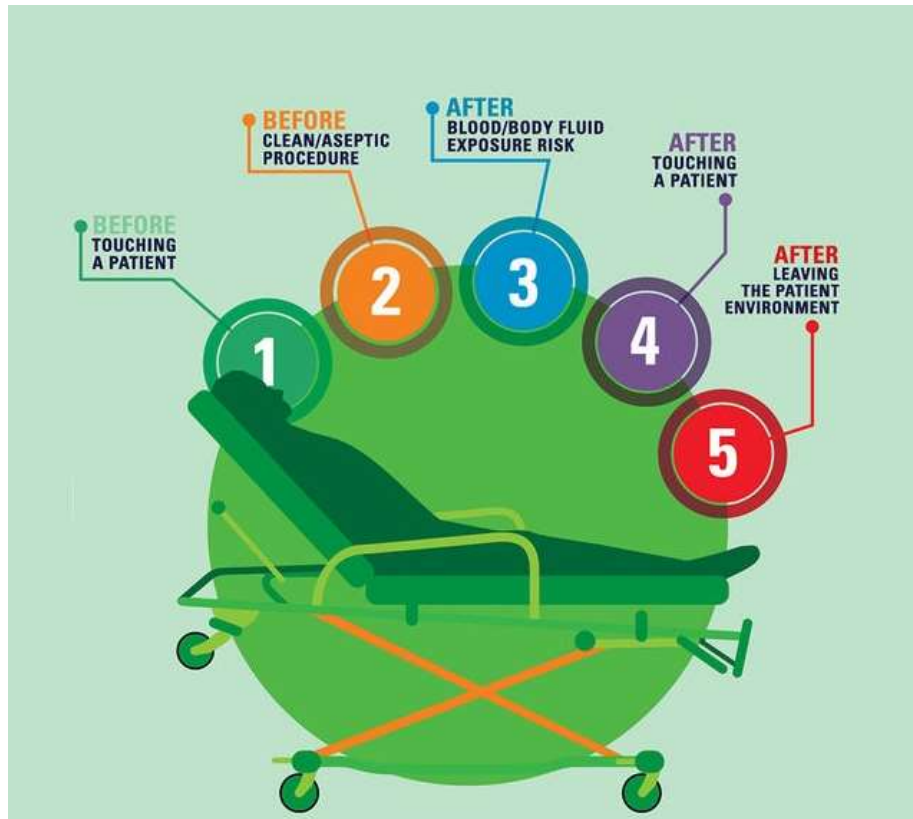

1	BEFORE TOUCHING A PATIENT	WHEN? Clean your hands before touching a patient when approaching her/him.	WHY? To protect the patient against harmful germs carried on your hands.
2	BEFORE CLEAN/ASEPTIC PROCEDURE	WHEN? Clean your hands immediately before performing a clean/aseptic procedure.	WHY? To protect the patient against harmful germs, including the patient's own, from entering his/her body.
3	AFTER BODY FLUID EXPOSURE RISK	WHEN? Clean your hands immediately after an exposure risk to body fluids (and after glove removal).	WHY? To protect yourself and the health-care environment from harmful patient germs.
4	AFTER TOUCHING A PATIENT	WHEN? Clean your hands after touching a patient and her/his immediate surroundings, when leaving the patient's side.	WHY? To protect yourself and the health-care environment from harmful patient germs.
5	AFTER TOUCHING PATIENT SURROUNDINGS	WHEN? Clean your hands after touching any object or furniture in the patient's immediate surroundings, when leaving – even if the patient has not been touched.	WHY? To protect yourself and the health-care environment from harmful patient germs.

Note that all these moments take place “Where the patient is”

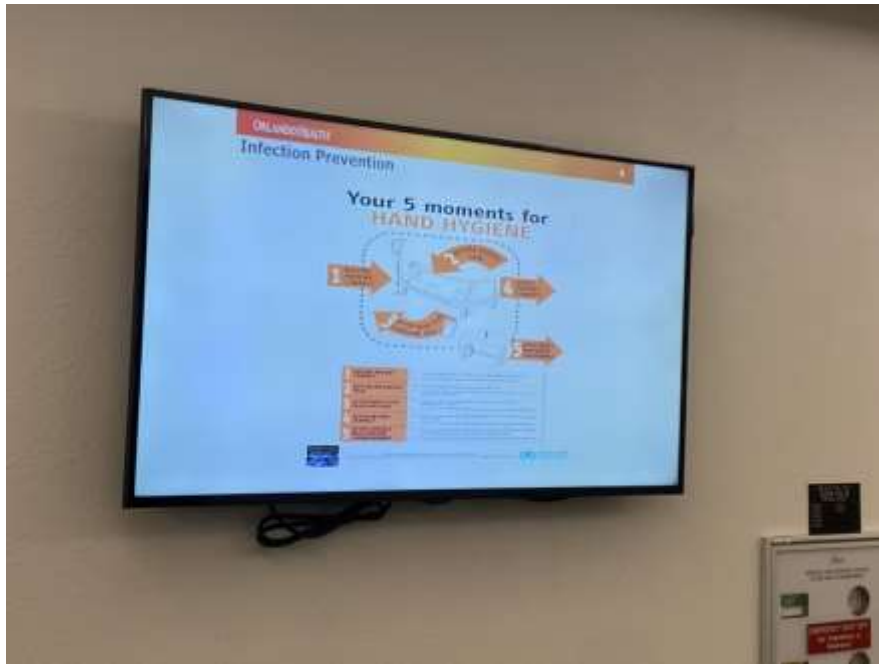

This is an international issue....
not just in our back yard

15-20 seconds of vigorous hand washing
with soap and water is recommended
to effectively kill germs! – cdc.gov



WHAT CAN THE A & D COMMUNITY DO TO HELP?

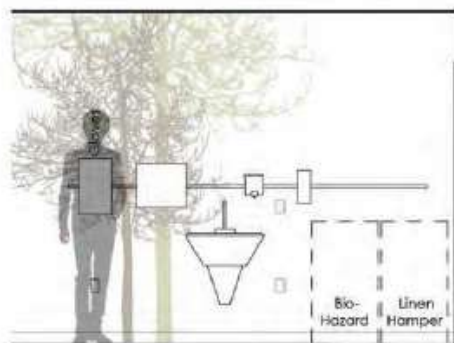
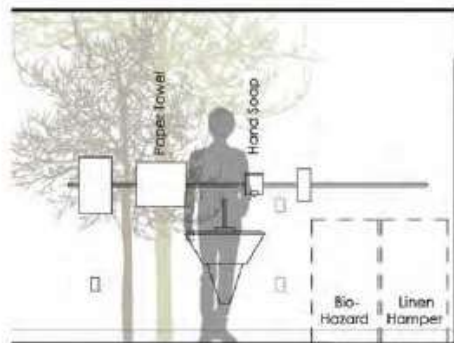
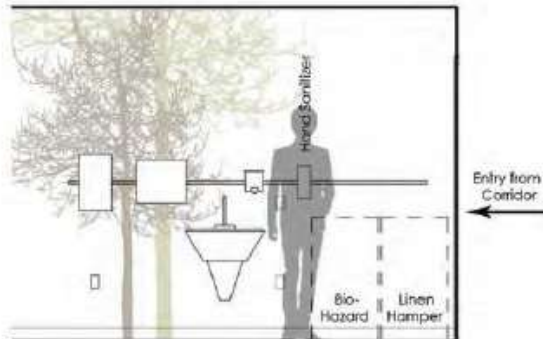

Harley Ellis Devereaux Standard Process Handwashing System in Patient Rooms; All new patient care units

EBD Goal:

To create a standard process that facilitates the practice of appropriate hand washing prior to caregiver interaction with the patient.

Published by The Center for Health Design, 2013

PROBLEM: Per the CDC, many studies have shown that the bacteria that cause hospital-acquired infections are most frequently spread from one patient to another on the hands of healthcare workers.

SOLUTION: Create a standard directional flow with easy access to sink and hand washing accessories at the room entry. "...placing the hand washing accessories on an equipment rail allows adjustment in the system without creating damage to the wall and potential home for pathogens."

FINANCIAL RESPONSIBILITY



BUT.....

If the Purchasing Department **saves \$40,000.00 per year** by re-negotiating a new contracts for foam, changing from Brand A to Brand B

Facilities Management needs to:

- Remove old dispenser
- Patch damage caused by removal
- Wait for drywall patch to dry
- Sand drywall
- Paint drywall.....but you have to find paint which matches.
- Call EVS for a terminal clean where drywall was repaired
- Loss of revenue when bed is down due to repair
\$90,000.00 to implement the change.....



THEN HOW MUCH HAS THE OWNER REALLY SAVED???



Double-sided sticky tape and dry-wall have never, nor will ever be compatible with each other.

These repairs will **ALWAYS** be expensive





We also know that If you can't paint behind it,
you can't clean behind it.



Low cost, aesthetic solutions are easily incorporated in to any design in order to Preserve the value of the owner's investment.





An equipment management strategy will save owners significant amounts of time and money by easily placing and re-placing the required PPE tools at the appropriate points of care.





T.C.O. (Total Cost of Ownership)

TOTAL COST OF OWNERSHIP (250 BED EXAMPLE)

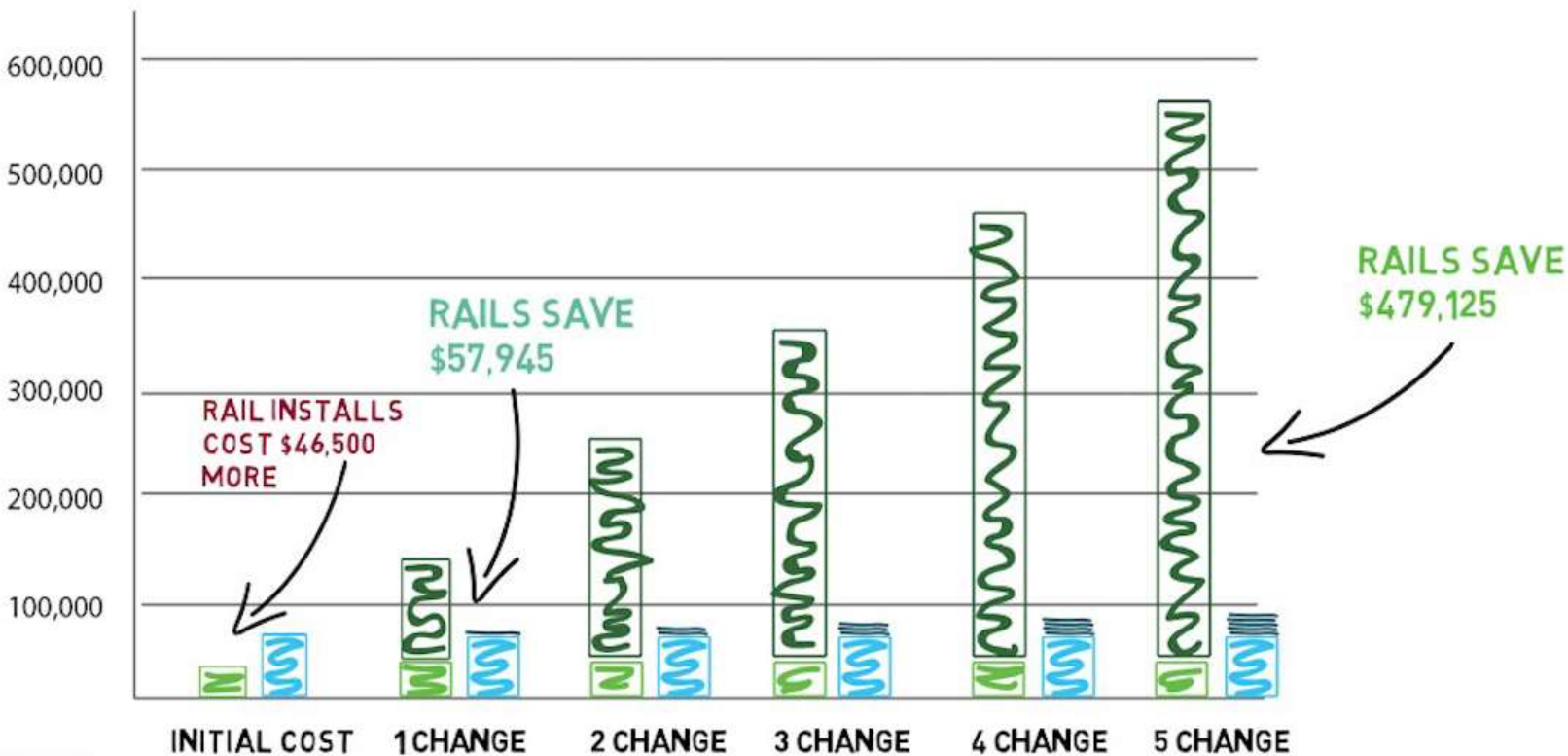

 WALL-MOUNTED

 RAIL-MOUNTED

HOSPITALS AVERAGE AT LEAST 1 CONTRACT CHANGE PER YEAR



An Equipment Management Strategy will impact infection control initiatives, by placing devices where they are needed most





EVERY healthcare environment can use
a rail system for infection control....
If It's On The Wall, It's On A Rail!

The ability to clean an environment has a MAJOR roll to play in complying with infection control initiatives

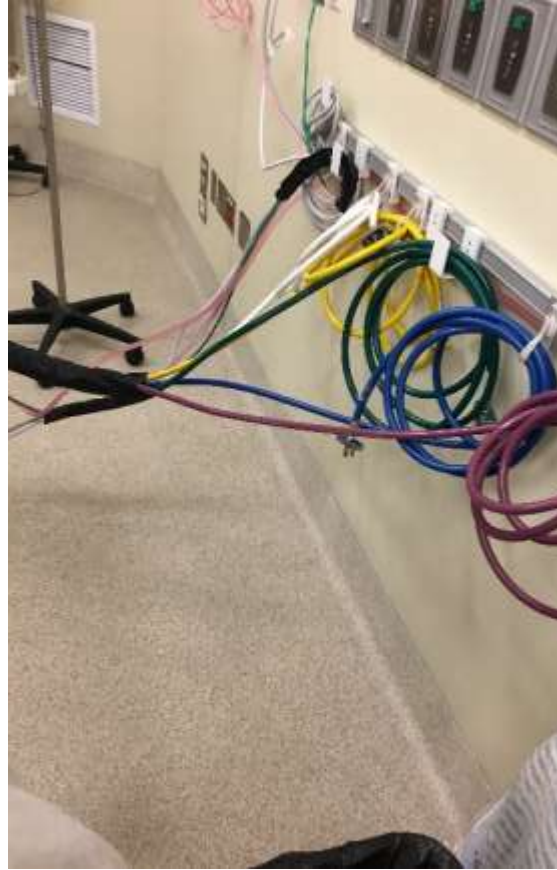



Keep equipment and cables off the floor so housekeeping can thoroughly clean.

Healthcare facilities must be prepared to terminally clean any patient room after discharge of an infectious patient.





Rails and adapters are **100% recyclable** and made from up to **64% recycled material**.

Sustainability and Value

What other tools or devices in healthcare have a **30 year life expectancy?**

Rail and gas blocks installed 1982

Diagnostic instruments mounted 2014

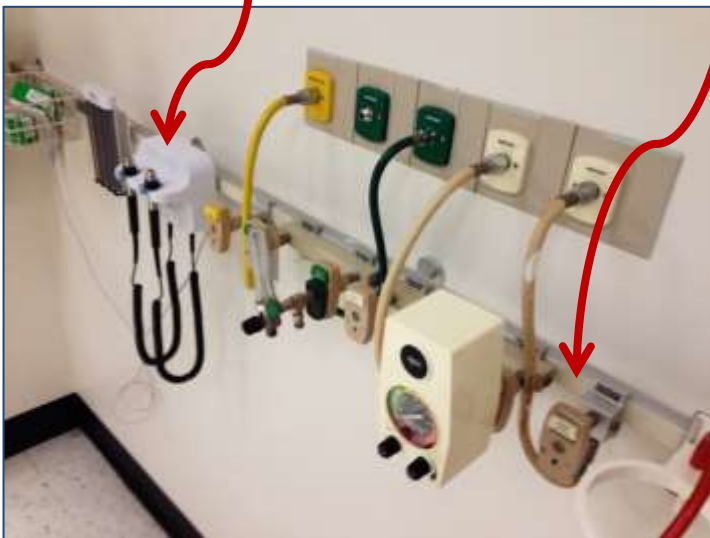



"LEAN" is the systematic method for waste minimization within a process without sacrificing productivity.

What is **LEAN SIX SIGMA**?

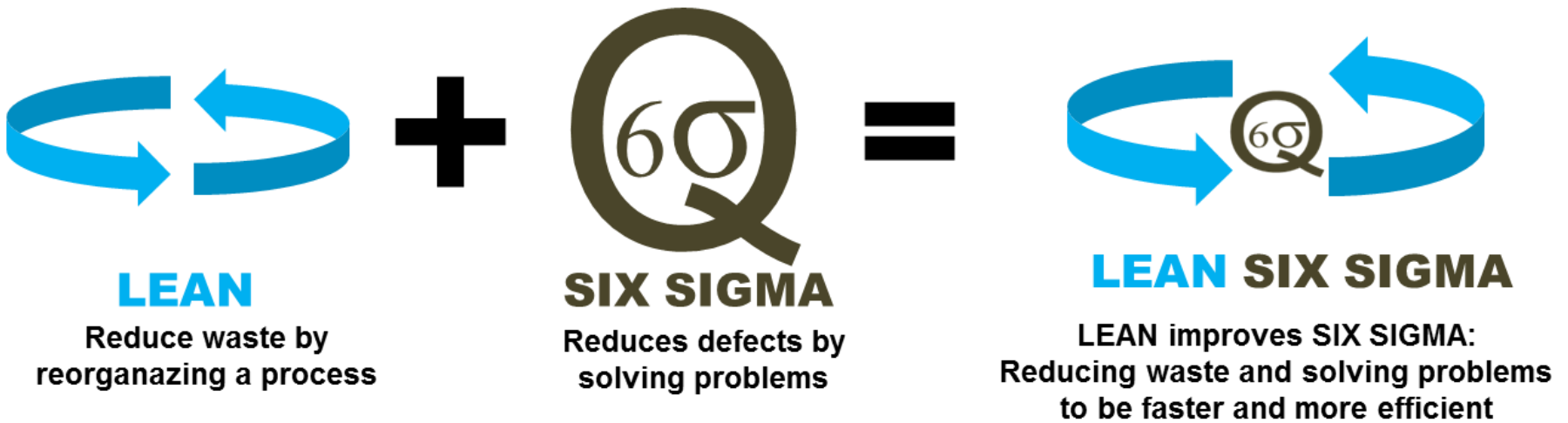

Because of its Toyota heritage, many people use Japanese phrases in LEAN planning: LEAN evaluation and process improvement must start where the work takes place (Gemba). In a healthcare facility, **"Healthcare"** takes place where the patient is.



KEY COMPONENTS
of process improvement
for clinicians at the bedside
are providing:

WHAT they need

WHERE they need it

WHEN they need it





In this real-world scenario, LEAN Implementation reduced inventory by 60% and 25 square feet of area was re-captured.

WORKFLOW MATTERS

An Equipment Management Strategy supports
Kaizen Process Improvement Initiatives

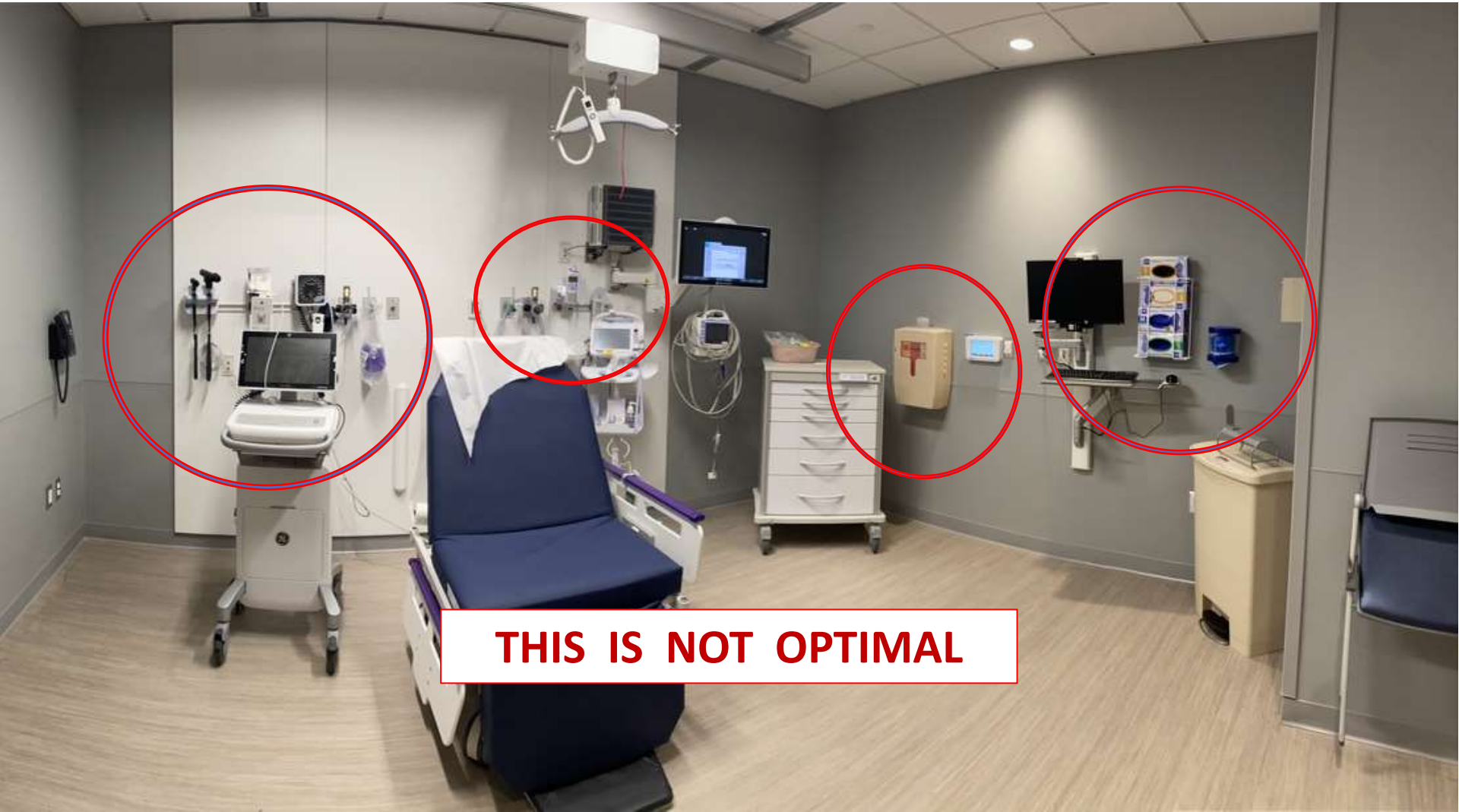

THIS IS NOT OPTIMAL



Putting technology and PPE devices readily available to personnel leads to improved hygiene practices and reduced HAI's. **A room re-configuration is easily accomplished** by simply re-positioning product on the rails.





“It always works on paper”. Quoted by U.S. Army Sargent Markum
Should it not work in the real world as well.

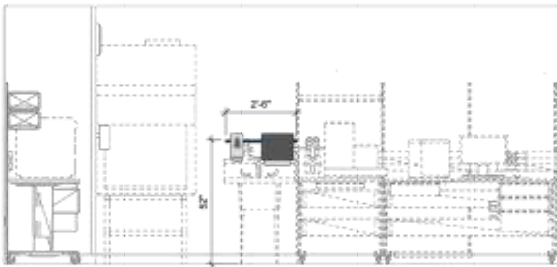

LABORATORY ROOM - TYPICAL

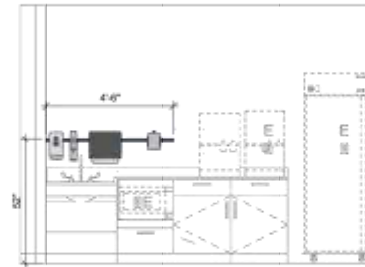

NOUR ROOM - TYPICAL

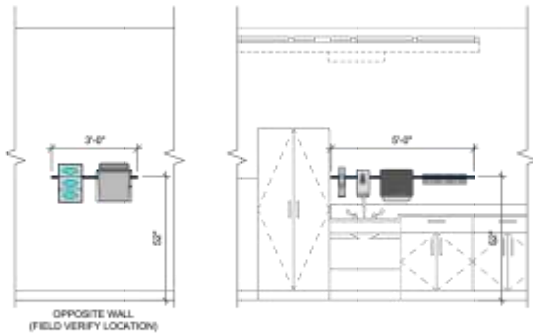

RADIOLOGY - TYPICAL

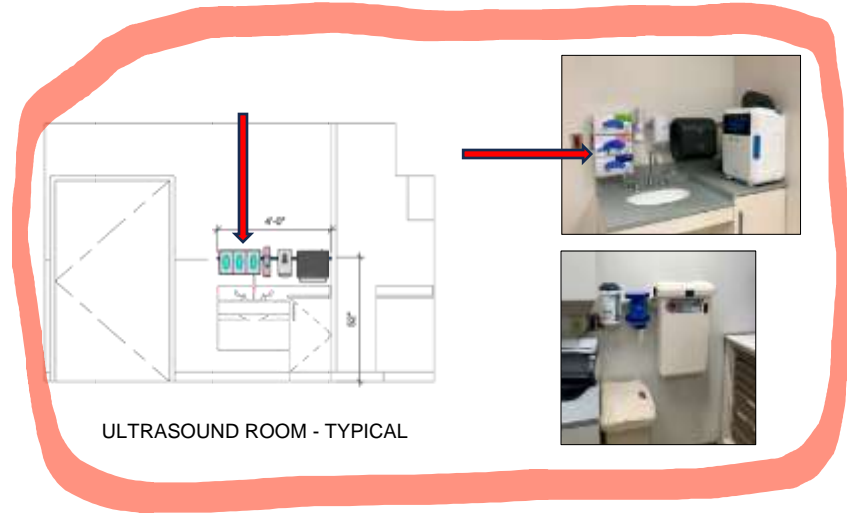

ULTRASOUND ROOM - TYPICAL

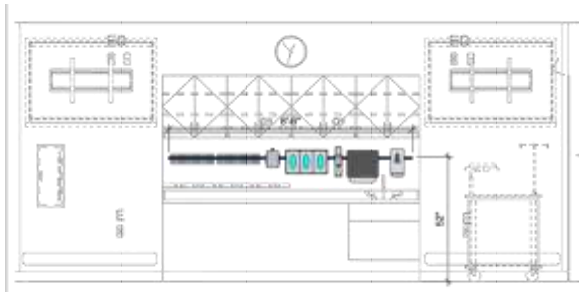

POCT ROOM - TYPICAL

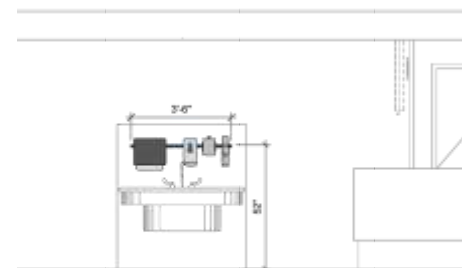

NURSE STATION - TYPICAL



It always works on paper.....

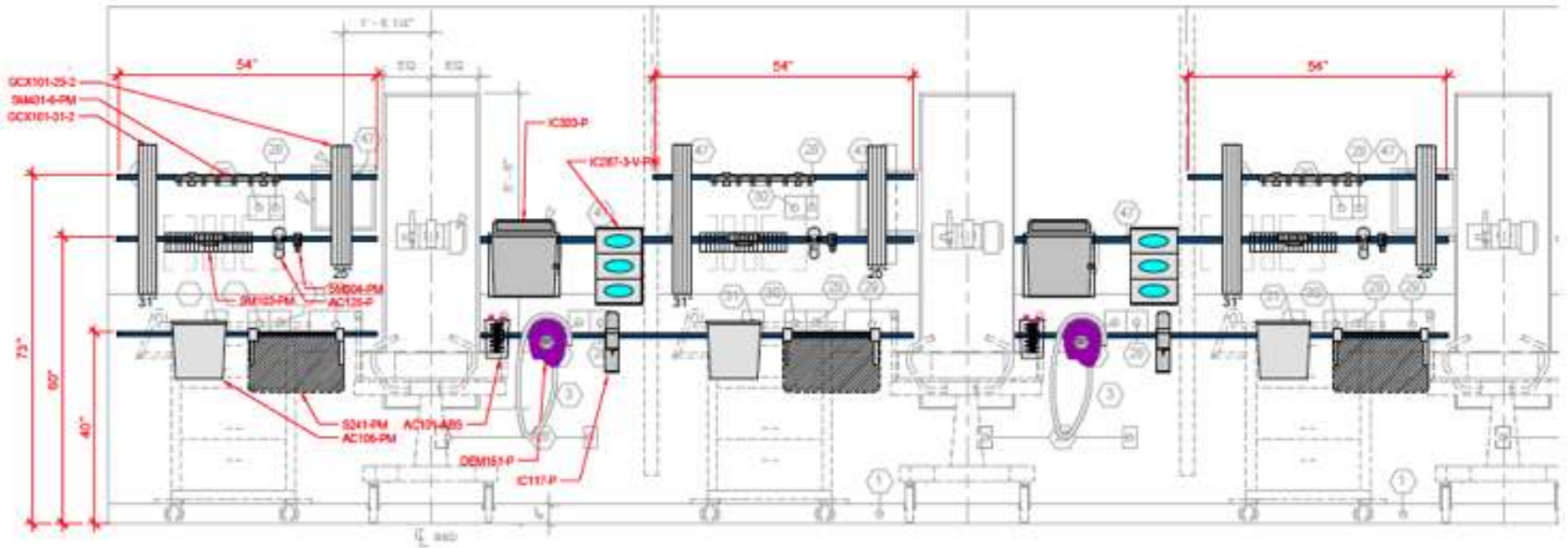

PHASE 1 RECOVERY HEADWALL AT BAYS
SCALE: 1/2" = 1'-0"

PHASE 1 - RECOVERY BAY
ROOM # 3133, 3134, 3135 & 3136

TYPICAL ELEVATION

PACKAGE:

APPROVAL DATE:



SCALE: N.T.S

REV 2: 9-8-22

DATE: 3-21-22

REV 3: 10-12-22

REV 1: 7-15-22

REV 4:

IE.9

SHEET NO.



In this case, the **CLINICIANS** simultaneously set up 3 side by side beds in different configurations of accessories.

THEY made the decisions about **THEIR** environment based on the **REAL** space **THEY** work in.

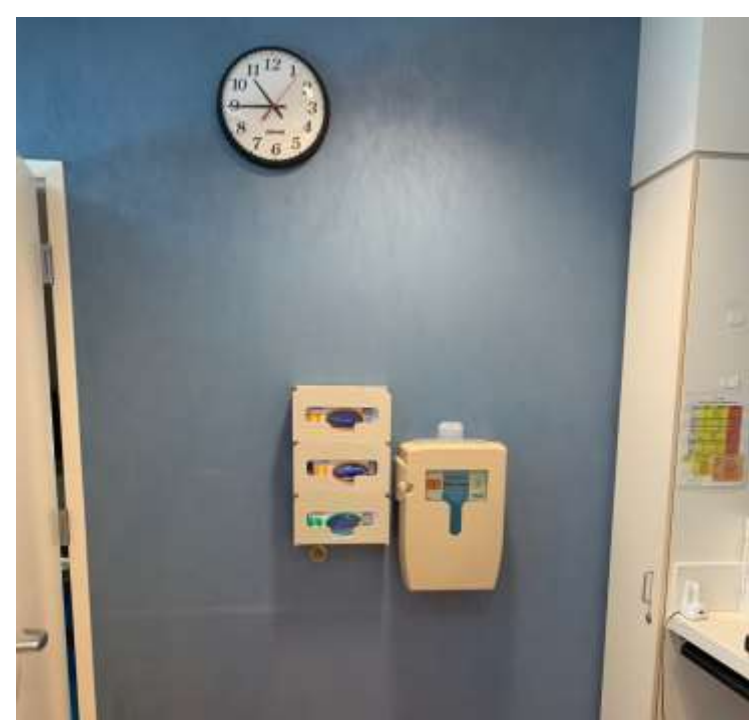

Consolidation and optimal device placement is easily accomplished post occupancy when using an equipment Rail system.

CONDUCT “Pre-Hospital” evaluations to identify what items need to be managed at workstations and then:

CHALLENGE users to define and create solutions to adapt to their needs





Non-Invasive medical gas expansion as a short term “problem solving” solution with an Equipment Management Strategy



PROBLEMS:

- Compromised Safety Issues
- Leaking Gas Outlets – Expensive and Repetitive Repairs



SOLUTIONS:

- Gas expansion for any type of outlet
- Splitter blocks on the rail **remove load from wall outlets**, eliminating leaks



Non-Invasive medical gas expansion is used as part of “phased” construction projects, shortening renovation times, and assisting in easy “temporary” re-location of “High Acuity” departments into lesser acute spaces.



The new FGI guidelines for Emergency Conditions also makes reference to incorporating means to Rapidly deploy medical gas delivery systems.

Figure 2-11: Medical Gas Expansion Rail



Integration by design of an equipment management rail allows for safe and clinically appropriate on-demand gas expansion.



Integrate equipment management tools with 3rd party wall systems to preserve the value of the owner's investment.



What is the **TRUE COST OF OWNERSHIP**, of repairing things that can't be fixed easily or inexpensively?

What is the **TRUE COST** of maintaining high quality finishes?

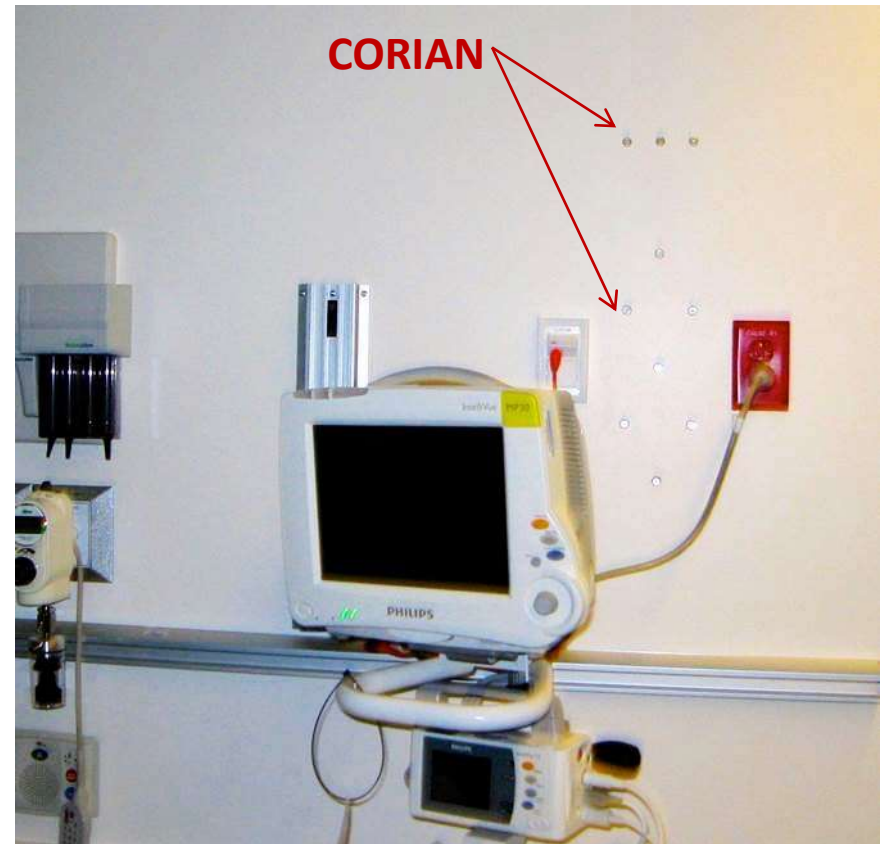



How do wall penetrations effect acoustics?
Sound transmission through the wall?
Your STC ratings?



The only constant
in Healthcare is change!



VALUE ENGINEERING EMPLOYED THE BEST WAY

Same
department,
7 years post
occupancy



This provider has had **ZERO COST OF OCCUPANCY** related to the physical space of a 36 bed Pre/Post-Op In-Hospital outpatient facility



REGARDLESS OF ACUITY OR COMPLEXITY



GIVING CLINICAL TEAMS THE MEANS TO MANAGE THE
POST OCCUPANCY REAL WORLD ENVIRONMENT
SUPPORTS ALL ASPECTS OF HEALTHCARE.



INCORPORATE tools
to manage evolving
technology and user
demand



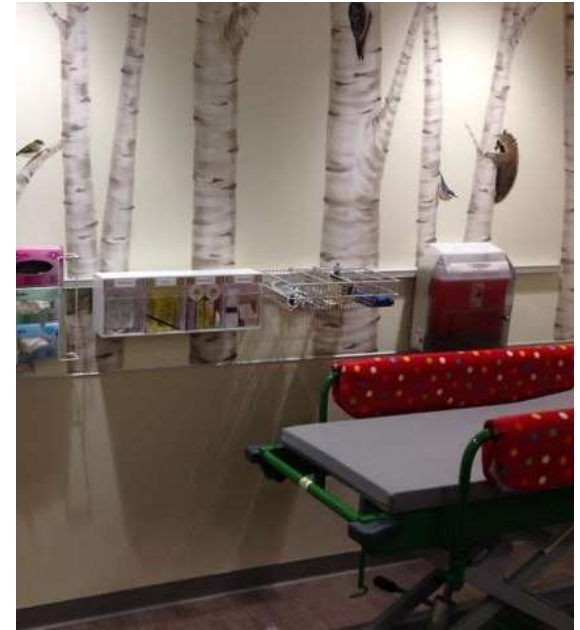

PRESERVE your design
intent against the ruin
of inevitable changes



APPLY Equipment
Management Tools
to organize supplies
and inventory

Equipment management for diagnostic instruments



BEHAVIORAL HEALTH “LITE” a.k.a “SAFE” ROOMS ON DEMAND



Mobile Equipment Management solutions to remove and manage devices from any patient room when the room needs to support behavioral health and not pre-designed or planned for that purpose.



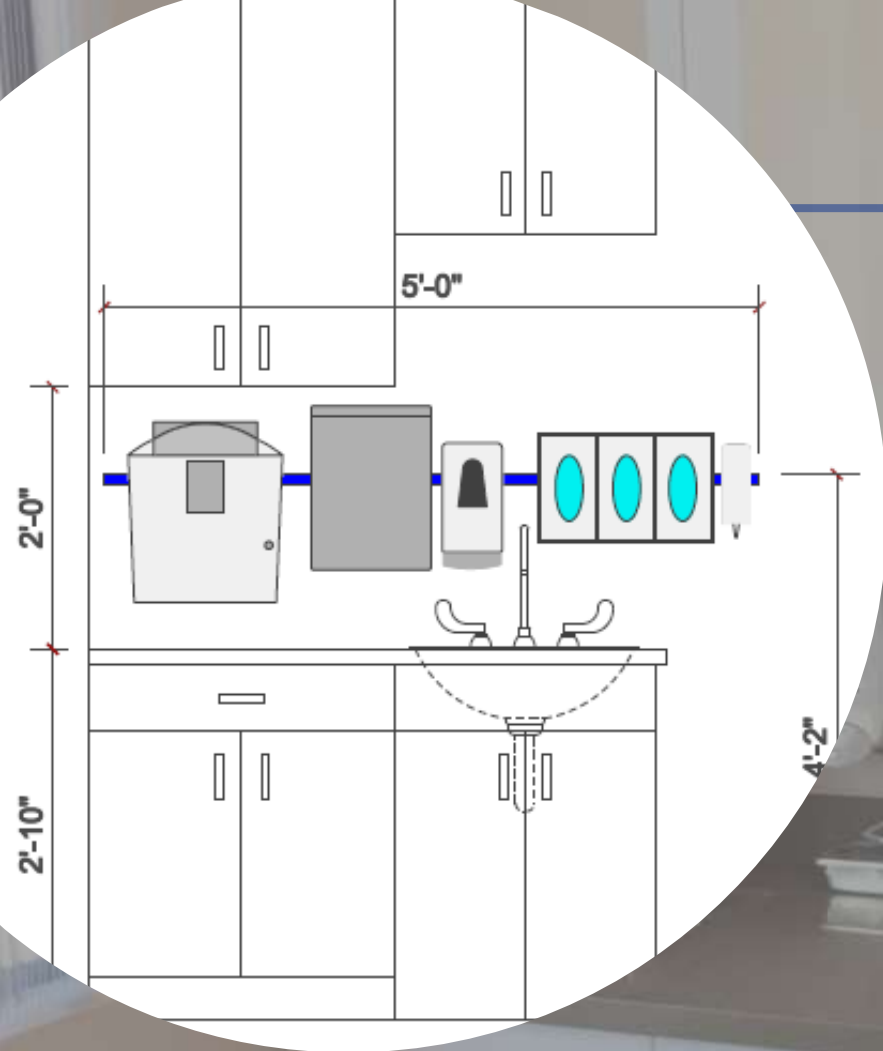

According to **NIOSH**, an ideal standing installation height for a fixed sharps container is **52" – 56"** from the floor.

Apply Equipment Management Tools for infection control devices.

Apply Equipment Management Tools for renovations of rooms with existing “older” headwall systems..





Apply Equipment
Management Tools for use
in the OR

Give the lead aprons a home....



....or they will find one





CHANGE COSTS MONEY.

The REAL question of the day is.....

Can your facility afford NOT TO implement an Equipment Management Strategy at Master Planning?

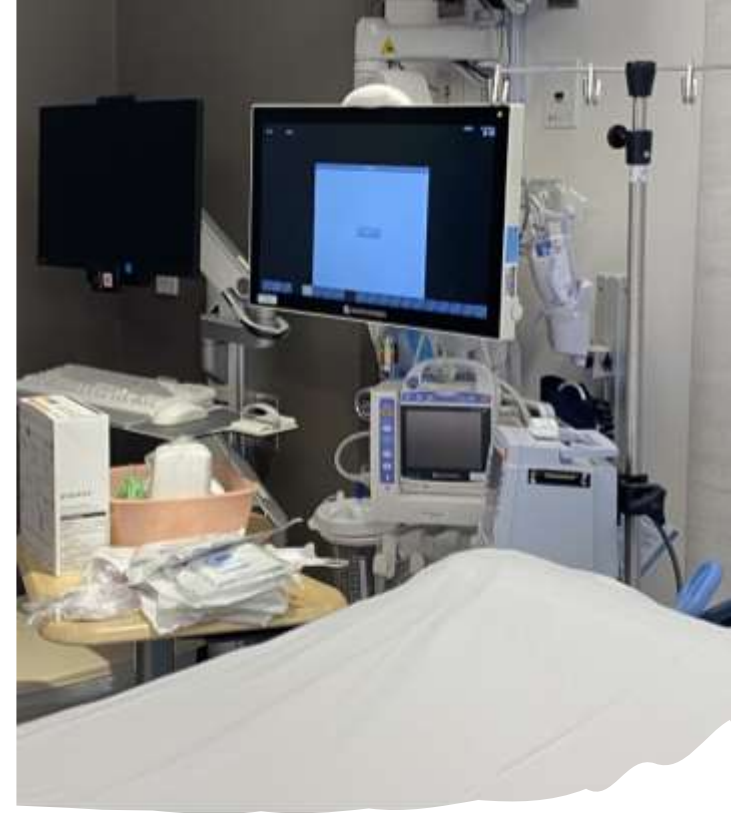

.....or can they afford the consequences if they don't!

This concludes our CEU Presentation.

We are pleased to be your partner in advancing the state of the art of healthcare design and delivery.





AMERICAN OWNED
AMERICAN MADE
APPLICATIONS FOR THE WORLD

Paladin Healthcare represents the PAST, the PRESENT and FUTURE of Equipment Management in Medical Facility Design.

We are the leading subject matter expert in the field of equipment management design and application.

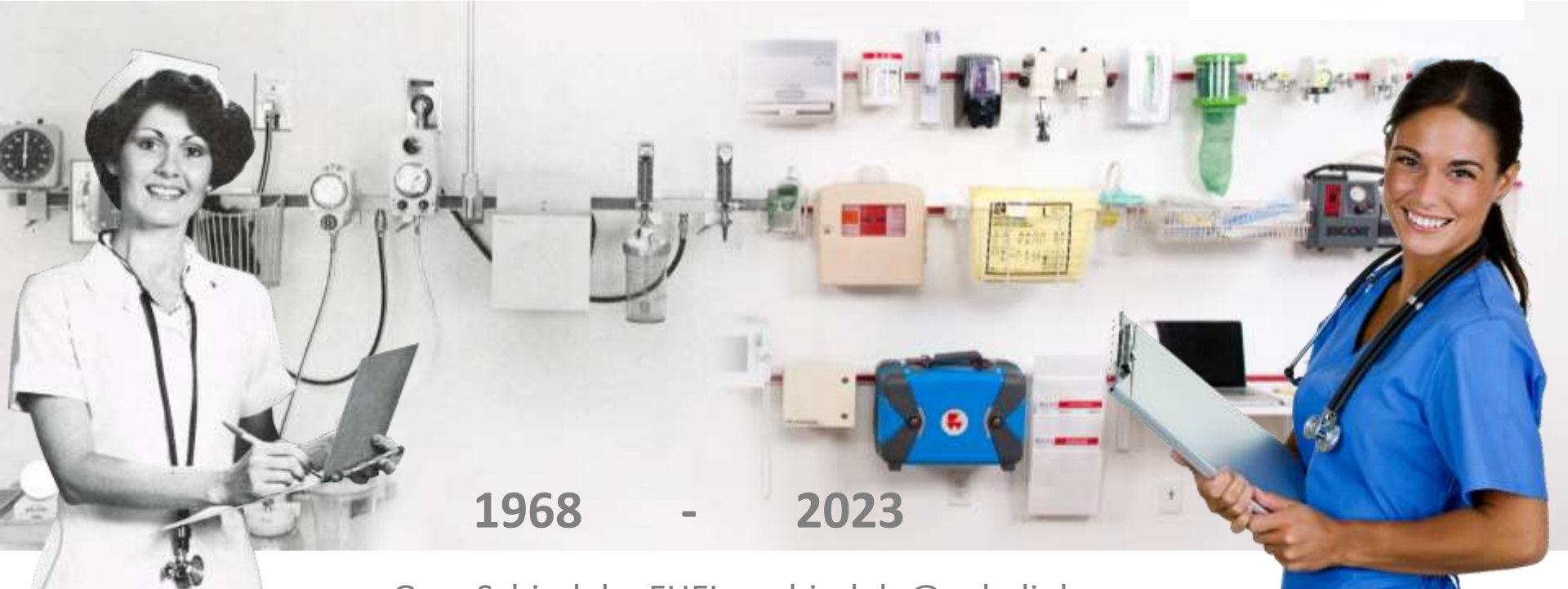

Gary Schindele, FHF, gschindele@paladinhc.com